

Quick Start Guide

Viglen Product Description: Intel D925XECV2 Motherboard

Viglen Order Code: PMPCV201

Viglen System: Genie Pro(S775)

- Product photo



Product specification.

Motherboard Form Factor	D925XECV2: ATX (10.20 inches by 9.60 inches [259.08 millimetres by 243.84 millimetres])																																																																														
Motherboard chipset	Intel® 925XE Chipset, consisting of: . Intel® 82925XE Memory Controller Hub (MCH) . Intel® 82801FR I/O Controller Hub (ICH6-R) . 8 Mbit Firmware Hub (FWH)																																																																														
CPU connector type (s370, slot1 etc)	LGA775 socket																																																																														
Number of CPUs supported	1																																																																														
If >1 does it require a terminator?	No																																																																														
Supported CPU types (C, P3 or P4 etc)	P4																																																																														
Supported CPU speeds	<table border="1"> <thead> <tr> <th>Processor Family</th> <th>Processor Number</th> <th>Processor Speed</th> <th>System Bus Frequency</th> <th>L2 Cache Size</th> <th>L3 Cache Size</th> </tr> </thead> <tbody> <tr> <td rowspan="2">Intel® Pentium® 4 Extreme Edition</td> <td></td> <td>3.46 GHz</td> <td>1066 MHz</td> <td>512 KB</td> <td>2 MB</td> </tr> <tr> <td></td> <td>3.40 GHz</td> <td>800 MHz</td> <td>512 KB</td> <td>2 MB</td> </tr> <tr> <td rowspan="10">Intel® Pentium® 4</td> <td>570J</td> <td>3.80 GHz</td> <td>800 MHz</td> <td>1 MB</td> <td></td> </tr> <tr> <td>560J</td> <td>3.60 GHz</td> <td>800 MHz</td> <td>1 MB</td> <td></td> </tr> <tr> <td>560</td> <td>3.60 GHz</td> <td>800 MHz</td> <td>1 MB</td> <td></td> </tr> <tr> <td>550J</td> <td>3.40 GHz</td> <td>800 MHz</td> <td>1 MB</td> <td></td> </tr> <tr> <td>550</td> <td>3.40 GHz</td> <td>800 MHz</td> <td>1 MB</td> <td></td> </tr> <tr> <td>540J</td> <td>3.20 GHz</td> <td>800 MHz</td> <td>1 MB</td> <td></td> </tr> <tr> <td>540</td> <td>3.20 GHz</td> <td>800 MHz</td> <td>1 MB</td> <td></td> </tr> <tr> <td>530J</td> <td>3 GHz</td> <td>800 MHz</td> <td>1 MB</td> <td></td> </tr> <tr> <td>530</td> <td>3 GHz</td> <td>800 MHz</td> <td>1 MB</td> <td></td> </tr> <tr> <td>520J</td> <td>2.80 GHz</td> <td>800 MHz</td> <td>1 MB</td> <td></td> </tr> <tr> <td>520</td> <td>2.80 GHz</td> <td>800 MHz</td> <td>1 MB</td> <td></td> </tr> </tbody> </table>						Processor Family	Processor Number	Processor Speed	System Bus Frequency	L2 Cache Size	L3 Cache Size	Intel® Pentium® 4 Extreme Edition		3.46 GHz	1066 MHz	512 KB	2 MB		3.40 GHz	800 MHz	512 KB	2 MB	Intel® Pentium® 4	570J	3.80 GHz	800 MHz	1 MB		560J	3.60 GHz	800 MHz	1 MB		560	3.60 GHz	800 MHz	1 MB		550J	3.40 GHz	800 MHz	1 MB		550	3.40 GHz	800 MHz	1 MB		540J	3.20 GHz	800 MHz	1 MB		540	3.20 GHz	800 MHz	1 MB		530J	3 GHz	800 MHz	1 MB		530	3 GHz	800 MHz	1 MB		520J	2.80 GHz	800 MHz	1 MB		520	2.80 GHz	800 MHz	1 MB	
Processor Family	Processor Number	Processor Speed	System Bus Frequency	L2 Cache Size	L3 Cache Size																																																																										
Intel® Pentium® 4 Extreme Edition		3.46 GHz	1066 MHz	512 KB	2 MB																																																																										
		3.40 GHz	800 MHz	512 KB	2 MB																																																																										
Intel® Pentium® 4	570J	3.80 GHz	800 MHz	1 MB																																																																											
	560J	3.60 GHz	800 MHz	1 MB																																																																											
	560	3.60 GHz	800 MHz	1 MB																																																																											
	550J	3.40 GHz	800 MHz	1 MB																																																																											
	550	3.40 GHz	800 MHz	1 MB																																																																											
	540J	3.20 GHz	800 MHz	1 MB																																																																											
	540	3.20 GHz	800 MHz	1 MB																																																																											
	530J	3 GHz	800 MHz	1 MB																																																																											
	530	3 GHz	800 MHz	1 MB																																																																											
	520J	2.80 GHz	800 MHz	1 MB																																																																											
520	2.80 GHz	800 MHz	1 MB																																																																												
Front side bus speed	800MHz, 533MHz and 1066MHz																																																																														
Number of PCI slots	4																																																																														
PCI slot speeds	33																																																																														
Number of PCI-E slots	1 x PCI-E x16 and 2 x PCI-E x1																																																																														
Number of AGP slots	0																																																																														
Number of AMR slots	0																																																																														
Additional slots	0																																																																														
On board video fitted? Type	No																																																																														
Ram size?	4GB																																																																														
Upgradeable?	Yes																																																																														
Onboard audio fitted? Type	Intel® High Definition Audio subsystem using the Realtek ALC860 audio codec.																																																																														
Front facing audio header and type	Yes																																																																														
Audio Upgradeable?	Yes via PCI/PCI-E																																																																														

Onboard network fitted? Type	Gigabit (10/100/1000 Mbps/sec) LAN subsystem using the Marvel* Yukon* 88E8050 PCI Express* Gigabit Ethernet Controller	
Number of network connections?	1	
Upgradeable?	Via PCI or PCI-E	
Onboard SCSI fitted? Type	No	
No of channels?	N/A	
Manufacturer?	N/A	
Model Number?	N/A	
Speed?	N/A	
Number of IDE channels	1	
Number of SATA channels	4	
Maximum number of disks	6 (2 x IDE 2 x SATA) this would require full height ATX case	
Rear I/O connectors	4 x USB 2	1 x MIC
	Note 2 x USB 2 front headers	1 x audio out
	1 x serial	1 x audio in
	1 x parallel	1 x PS2 mouse
	1 x RJ45 LAN	1 x PS2 keyboard
Memory type	240-pin DDR2 SDRAM DIMM sockets DDR2 400 and DDR2 533	
For RIMMs install CRIMM in empty sockets	Na	
Number of memory sockets	Four 240-pin DDR2 SDRAM DIMM sockets	
Maximum memory support	Support for up to 4 GB of system memory	
Supported memory speed	DDR 2 5400and DDR2 533	
MTBF	105,577 hours.	

Note:

Trusted Platform Module (TPM)

The D925XECV2 motherboard incorporates the TPM “Trusted Platform Module”. The Trusted Platform Module is a component on the desktop board that is specifically designed to enhance platform security above-and-beyond the capabilities of today’s software by providing a protected space for key operations and other security critical tasks. Using both hardware and software, the TPM protects encryption and signature keys at their most vulnerable stages — operations when the keys are being used unencrypted in plain-text form. The TPM is specifically designed to shield unencrypted keys and platform authentication information from software-based attacks.

Warning of Potential Data Loss!

The D925XECV2 motherboard incorporates the TPM “Trusted Platform Module” this is disabled by default in the BIOS setup utility please refer to the accompanied D925XECV2 motherboard manual.pdf, TPMQuickReference.pdf and TPMFlyer.pdf.

Upgrading and ESD precautions

WARNING

Unplug the system before carrying out the procedures described in this document. Failure to disconnect power before you open the system can result in personal injury or equipment damage. Hazardous voltage, current, and energy levels are present in this product. Power switch terminals can have hazardous Voltages present even when the power switch is off.

The procedures assume familiarity with the general terminology associated with personal computers and with the safety practices and regulatory compliance required for using and modifying electronic equipment.

Do not operate the system with the cover removed. Always replace the cover before turning on the system.

As the colours of the wires in the mains lead of this computer may not correspond with the coloured markings identifying the terminals in your plug proceed as follows:

The wire which is coloured green-and-yellow must be connected to the terminal in the plug which is marked by the letter **E** or by the safety Earth symbol  or coloured green or green-and-yellow.

The wire which is coloured blue must be connected to the terminal which is marked with the letter **N** or coloured black.

The wire which is coloured brown must be connected to the terminal which is marked with the letter **L** or coloured red.

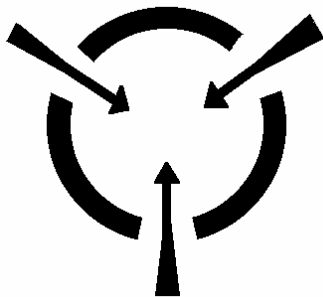

CAUTION!

The Viglen D925XECV2 motherboard and associated components are sensitive electronic devices. A small static shock from your body can cause expensive damage to your equipment.

Make sure you are earthed and free of static charge before you open the computer case. If you are unsure about upgrading your computer, return it to Viglen so a qualified engineer can perform the upgrade.

STEPS TO TAKE TO PREVENT STATIC DISCHARGE:

1. The best way to prevent static discharge is to buy an anti-static strap from your local electrical shop. While you are wearing the strap and it is earthed, static charge will be harmlessly bled to ground.
2. Do not remove the component from its anti-static protective packaging until you are about to install it.
3. Hold boards by the edges - try not to touch components / interface strips etc.

Note:

We recommend that you return your computer to the service department for upgrading. Any work carried out is fully guaranteed. Upgrades should only be carried out by persons who are familiar with handling IC's, as incorrect installation will invalidate the guarantee.

- System Board Components

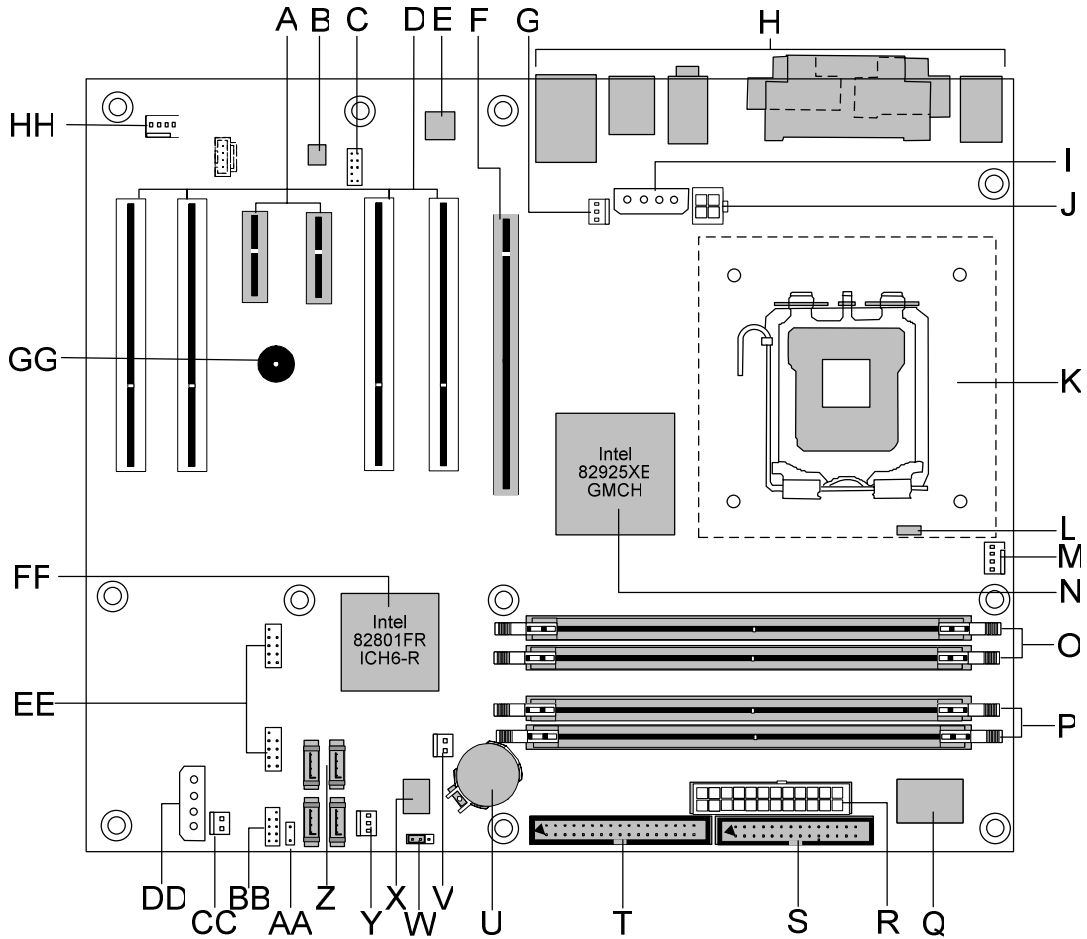

Figure 1 Motherboard Layout & Components

Table 2.

A	PCI Express x1 bus add-in card connectors	R	Power connector (24 way ATX2.2)
B	Realtek ALC860 audio codec	S	Diskette drive connector
C	Front panel audio connector	T	Parallel ATE IDE connector
D	PCI Conventional bus add-in card connectors	U	Battery
E	Marvell Yukon 88E8050 PCI Express Gigabit Ethernet Controller	V	Chassis intrusion connector
F	PCI Express x16 bus add-in card connector	W	BIOS Setup configuration jumper block
G	Rear chassis fan connector	X	4 Mbit Firmware Hub (FWH)
H	Back panel connectors	Y	Front chassis fan connector
I	Alternate power connector (not used)	Z	Serial ATA connectors
J	+12V power connector (ATX12V)	AA	Auxiliary front panel power LED connector
K	LGA775 processor socket	BB	Front panel connector
L	Hardware monitoring and fan control ASIC	CC	SCSI LED connector (optional)
M	Processor fan connector	DD	Auxiliary power connector (not to be used to power HDD's optical drive's etc)
N	Intel 82925XE MCH	EE	Front panel USB connectors
O	DIMM Channel A sockets	FF	Intel 82801FR I/O Controller Hub (ICH6-R)
P	DIMM Channel B sockets	GG	Speaker
Q	I/O controller	HH	Auxiliary rear fan connector

- Back Panel Connectors 5.1 Audio ALC860

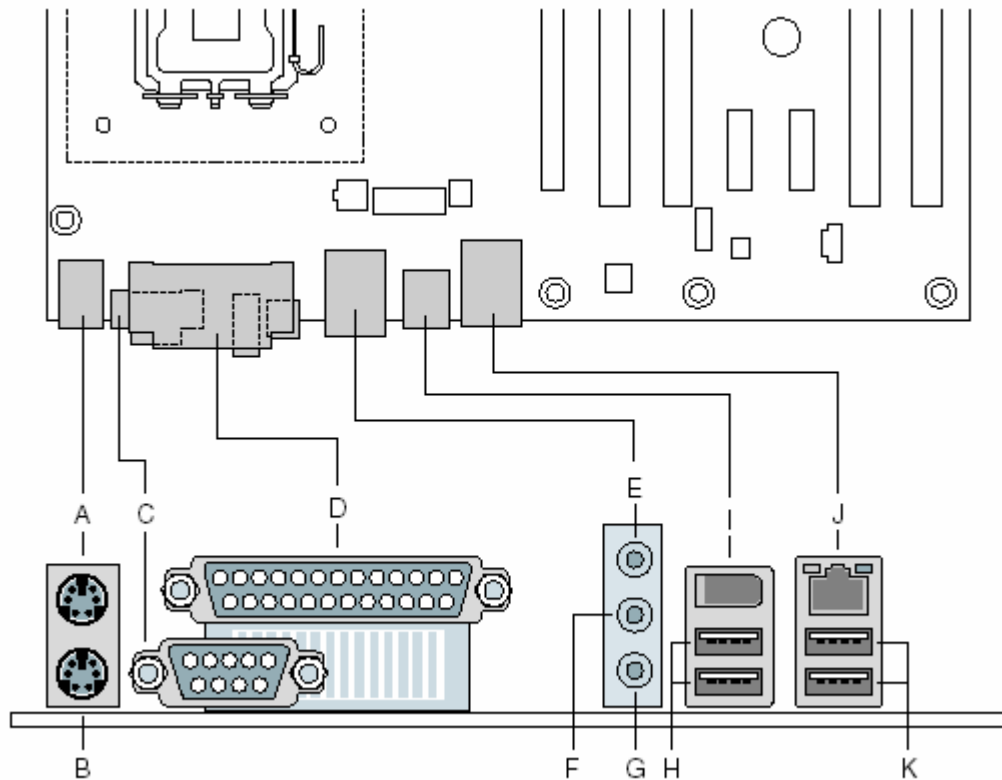

Figure 2. Back Panel Connectors.

Table 3.

Item	Description	Item	Description
A	PS/2* mouse port (Green)	G	Mic in/Retasking Port B (Pink)
B	PS/2 keyboard port (Purple)	H	USB ports (two)
C	Serial port A (Teal)	I	IEEE-1394a (optional)
D	Parallel port (Burgundy)	J	LAN
E	Audio line in/Retasking Port C (Blue)	K	USB ports (two)
F	Front left/right channel audio out/Two channel audio line out/Retasking Jack D [Lime green]		

Note: The back panel audio line out connector is designed to power headphones or amplified speakers only. Poor audio quality occurs if passive (non-amplified) speakers are connected to this output.

- **Front panel connections**

The following are all connectors situated along the front edge of the motherboard. They are often connected to buttons and LED's situated on the front panel.

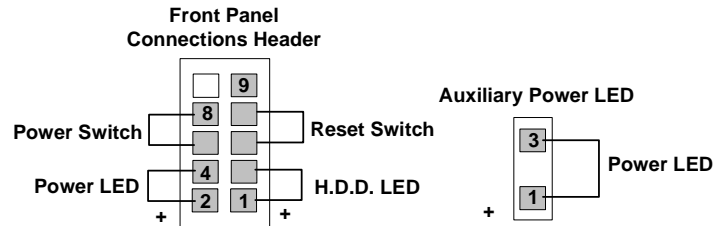

Figure 3. Front panel connectors

A-Hard Disk L.E.D. Connector

This goes to the Hard Disk L.E.D. on the front panel, which lights up when the IDE Hard Disk is in use.

B - Reset switch connector

When these pins are shorted, it will cause the computer to perform a cold reboot.

C - Power L.E.D.

This attaches to the power L.E.D on the front panel, to display if the computer is active or not.

D- Power On/Off

When these pins are shorted it turns the computer on and off.

- **Motherboard Connectors**

There are connectors on the motherboard for FAN, IDE, Power supply, CD audio, Floppy, IDE, & Front Panel Connectors. The location and/or details of these connections are shown below.

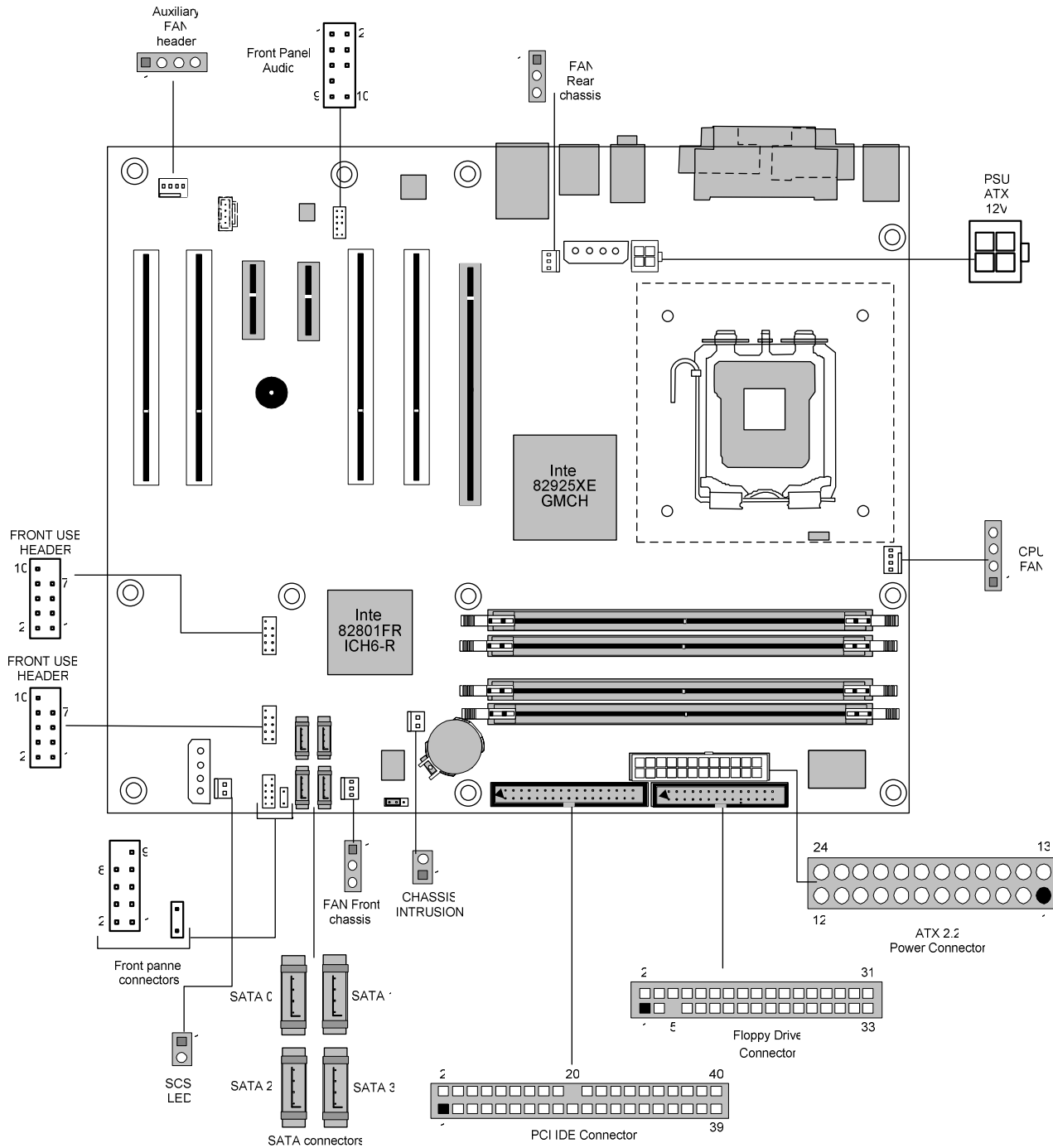

Figure 4. Motherboard Connectors

- **Jumper settings**

CAUTION Do not move any jumpers with the power on. Always turn off the power and unplug the power cord from the computer before changing a jumper setting. Otherwise, the board could be damaged.

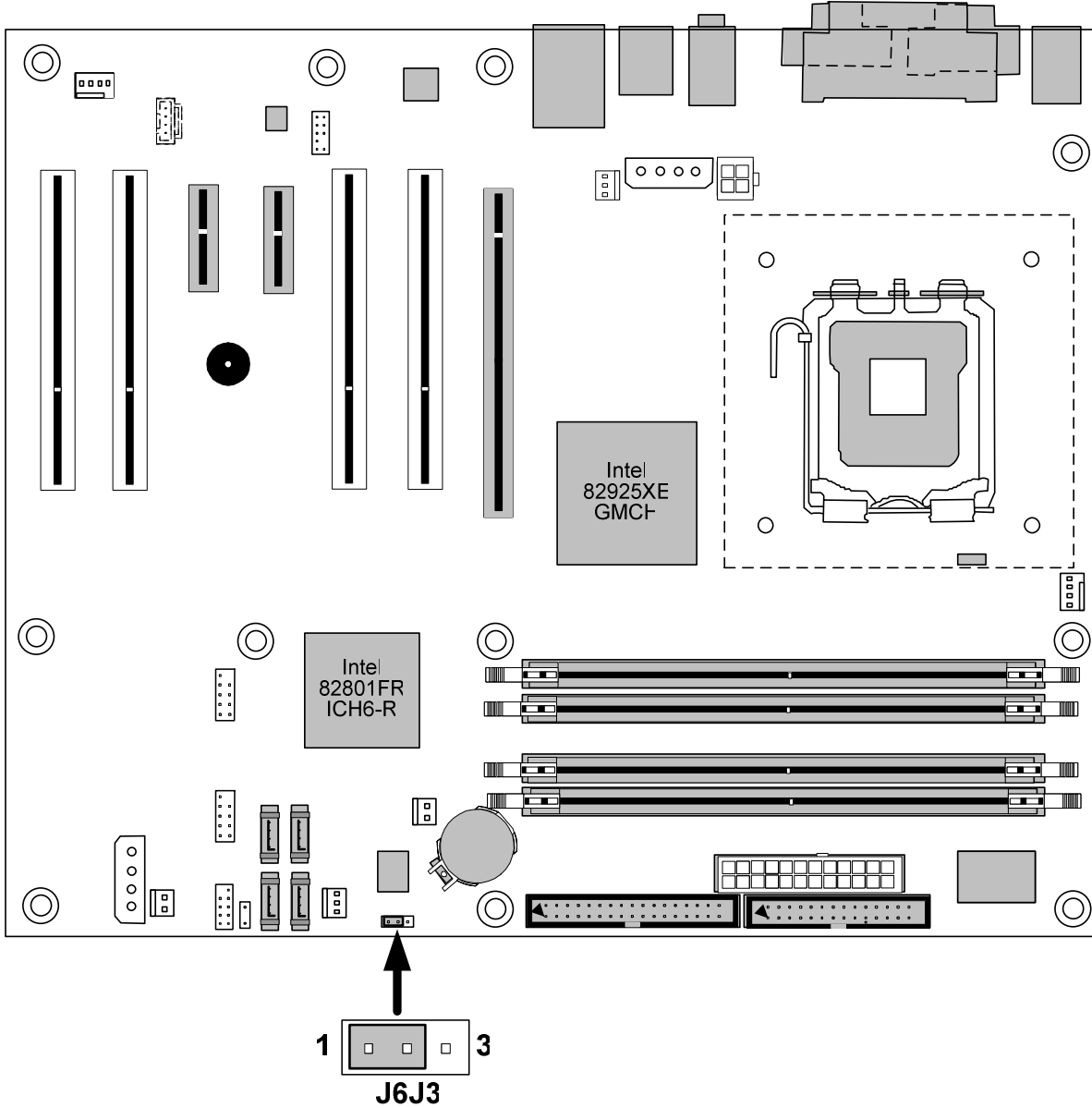
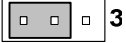

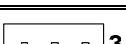

Figure 5. Motherboard jumper.

BIOS Setup Configuration Jumper (J6J3) Settings

The 3-pin jumper block determines the BIOS Setup program's mode. The table below describes the jumper settings for the three modes: normal, configure, and recovery. When the jumper is set to configure mode and the computer is powered-up, the BIOS compares the processor version and the microcode version in the BIOS and reports if the two match.

Table 4.

Function/Mode	Jumper Setting		Configuration
Normal	1-2	1  3	The BIOS uses current configuration information and passwords for booting.
Configure	2-3	1  3	After the POST runs, Setup runs automatically. The maintenance menu is displayed.
Recovery	None	1  3	The BIOS attempts to recover the BIOS configuration. A recovery diskette is required.

System Memory

The boards have four DIMM sockets and support the following memory features:

- 1.8 V and 1.9V DDR2 SDRAM DIMMs with gold-plated contacts
Note:3-3-3 memory timing with 1.9V DIMMs
- Unbuffered, single-sided or double-sided DIMMs with the following restriction:
Double-sided DIMMS with x16 organization are not supported.
- 4 GB maximum total system memory total amount of addressable memory.
- Minimum total system memory: 128 MB
- Non-ECC DIMMs
- Serial Presence Detect
- DDR2 533 MHz or DDR2 400 MHz SDRAM DIMMs

NOTES

- *Remove the PCI Express x16 video card before installing or upgrading memory to avoid interference with the memory retention mechanism.*
- *To be fully compliant with all applicable DDR SDRAM memory specifications, the board should be populated with DIMMs that support the Serial Presence Detect (SPD) data structure. This allows the BIOS to read the SPD data and program the chipset to accurately configure memory settings for optimum performance. If non-SPD memory is installed, the BIOS will attempt to correctly configure the memory settings, but performance and reliability may be impacted or the DIMMs may not function under the determined frequency.*

The following table lists the supported DIMM configurations.

Table 6.

DIMM Capacity	Configuration	SDRAM Density	SDRAM Organization Front-side/Back-side	Number of SDRAM Devices
128 MB	SS	256 Mbit	16 M x 16/empty	4
256 MB	SS	256 Mbit	32 M x 8/empty	8
256 MB	SS	512 Mbit	32 M x 16/empty	4
512 MB	DS	256 Mbit	32 M x 8/32 M x 8	16
512 MB	SS	512 Mbit	64 M x 8/empty	8
512 MB	SS	1 Gbit	64 M x 16/empty	4
1024 MB	DS	512 Mbit	64 M x 8/64 M x 8	16
1024 MB	SS	1 Gbit	128 M x 8/empty	8
2048 MB	DS	1 Gbit	128 M x 8/128 M x 8	16

Note: In the second column, "DS" refers to double-sided memory modules (containing two rows of DDR SDRAM) and "SS" refers to single-sided memory modules (containing one row of DDR SDRAM).

NOTE: *It is possible to install four 2048 MB (2 GB) modules for a total of 8 GB of system memory, however, only 4 GB of address space is available.*

- **Memory Configurations**

The Intel 82925XE MCH supports two types of memory organization:

- **Dual channel (Interleaved) mode.** This mode offers the highest throughput for real world applications. Dual channel mode is enabled when the installed memory capacities of both DIMM channels are equal. Technology and device width can vary from one channel to the other but the installed memory capacity for each channel must be equal. If different speed DIMMs are used between channels, the slowest memory timing will be used.

- **Single channel (Asymmetric) mode.** This mode is equivalent to single channel bandwidth operation for real world applications. This mode is used when only a single DIMM is installed or the memory capacities are unequal. Technology and device width can vary from one channel to the other. If different speed DIMMs are used between channels, the slowest memory timing will be used.

NOTE

The DIMM0 sockets of both channels are blue. The DIMM1 sockets of both channels are black.

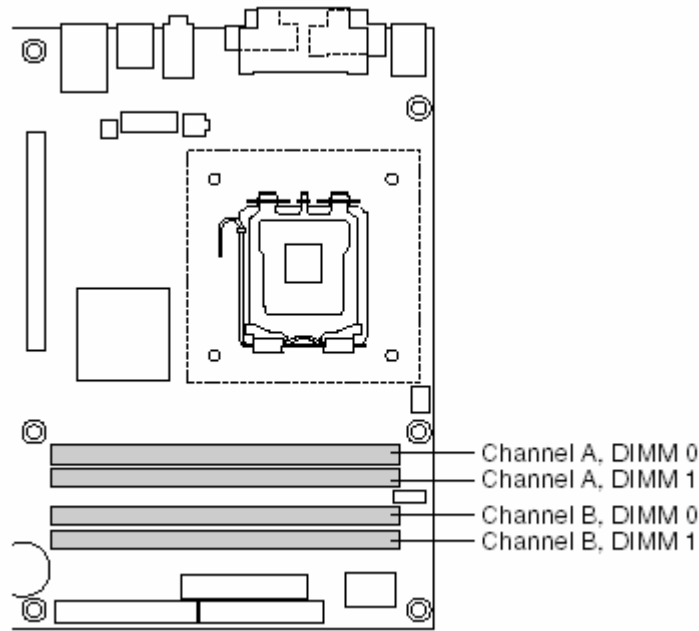

**Memory Channel and DIMM Configuration
Figure 6.**

Dual Channel (Interleaved) Mode Configurations

Figure 7 shows a dual channel configuration using two DIMMs. In this example, the DIMM0 (blue) sockets of both channels are populated with identical DIMMs.

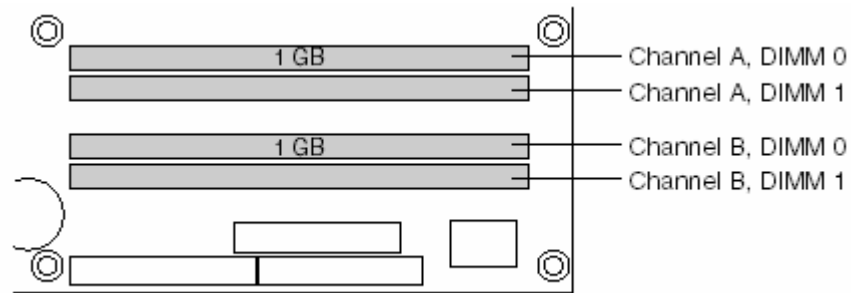

Figure 7. Dual Channel (Interleaved) Mode Configuration with Two DIMMs

Figure 8 shows a dual channel configuration using three DIMMs. In this example, the combined capacity of the two DIMMs in Channel A equal the capacity of the single DIMM in the DIMM0 (blue) socket of Channel B.



Figure 8. Dual Channel (Interleaved) Mode Configuration with Three DIMMs

Figure 9 shows a dual channel configuration using four DIMMs. In this example, the combined capacity of the two DIMMs in Channel A equal the combined capacity of the two DIMMs in Channel B. Also, the DIMMs are matched between DIMM0 and DIMM1 of both channels.



Figure 9. Dual Channel (Interleaved) Mode Configuration with Four DIMMs

Single Channel (Asymmetric) Mode Configurations

NOTE

Dual channel (Interleaved) mode configurations provide the highest memory throughput. Figure 10 shows a single channel configuration using one DIMM. In this example, only the DIMM0 (blue) socket of Channel A is populated. Channel B is not populated.

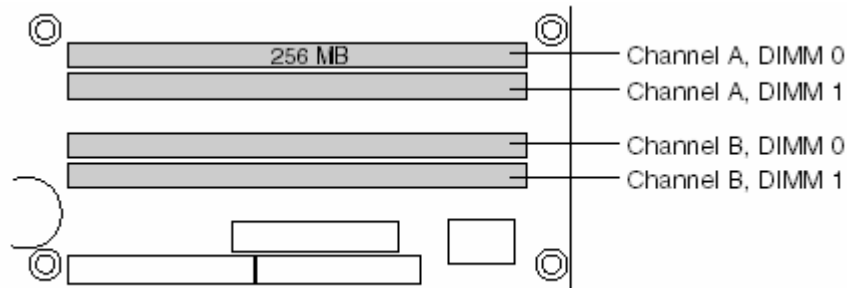

Figure 10. Single Channel (Asymmetric) Mode Configuration with One DIMM

Figure 11 shows a single channel configuration using three DIMMs. In this example, the combined capacity of the two DIMMs in Channel A does not equal the capacity of the single DIMM in the DIMM0 (blue) socket of Channel B.

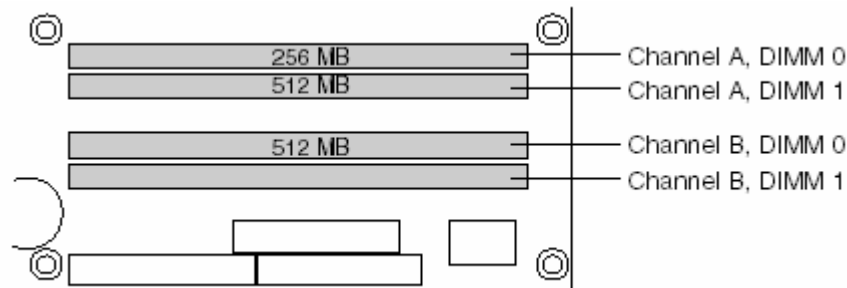

Figure 11. Single Channel (Asymmetric) Mode Configuration with Three DIMMs

Installing & Removing DDR2 SDRAM In-line Memory Modules (DIMMs)

Installing Memory

You can install from 128MB to 4GB of memory in the motherboard DIMM sockets.

The board has four 240-pin DDR2 SDRAM DIMM sockets.

The motherboard supports the following memory features:

- 240-pin 1.8volt only DIMMs with gold-plated contacts.
- 1.8 V and 1.9V DDR2 SDRAM DIMMs with gold-plated contacts
Note:3-3-3 memory timing with 1.9V DIMMs
- Non-ECC (64-bit).
- 128MB, 256MB, 512MB, 1GB and 2GB (in the future) modules.

When adding memory, follow these guidelines:

- The BIOS detects the size and type of installed memory.

Note:

DDR SDRAM's must meet the Version 1.0 June 2000 JEDEC Solid State Technology Association specifications for DDR200/266 SDRAM.

To install DIMMs, follow these steps:

1. Observe the precautions in "Upgrading and ESD precautions". Turn off the computer and all peripheral devices.
2. Remove the computer cover and locate the DIMM sockets.
3. Holding the DIMM by the edges, remove it from its antistatic package.
4. Make sure the clips at either end of the socket are pushed away from the socket.
5. Position the DIMM above the socket. Align the two small notches in the bottom edge of the DIMM with the keys in the socket. Insert the bottom edge of the DIMM into the socket.
6. When the DIMM is seated, push down on the top edge of the DIMM until the retaining clips at the ends of the socket snap into place. Make sure the clips are firmly in place.
7. Replace the computer cover.

Removing Memory

To remove a DIMM, follow these steps:

1. Observe the precautions in "Upgrading and ESD precautions".
2. Turn off all peripheral devices connected to the computer. Turn off the computer.
3. Remove the computer cover.
4. Gently spread the retaining clips at each end of the socket. The DIMM pops out of the socket. Hold the DIMM by the edges, lift it away from the socket, and store it in an antistatic package.
5. Reinstall and reconnect any parts you removed or disconnected to reach the DIMM sockets.

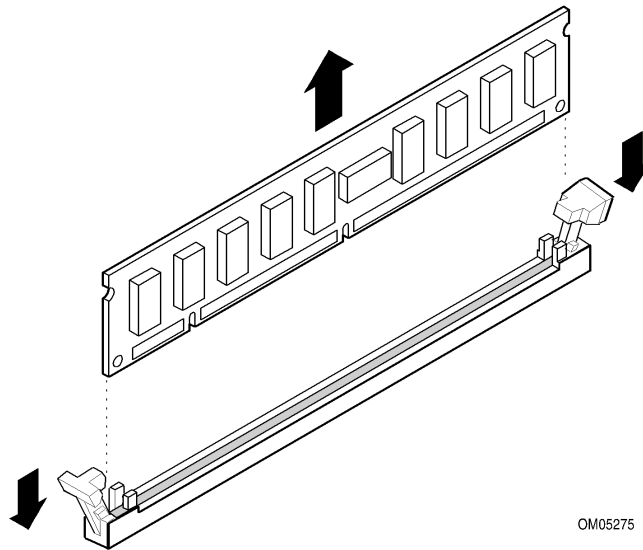

OM05275

Figure. 11. Removing DIMMs

BIOS Initial Release.

CV92510A.86A.0338

Drivers initial release

Windows 98SE, Windows ME, Windows NT4 Drivers are all not supported.

Windows* 2000 Drivers

INF: Intel® Chipset Software Installation Utility	6.2.1.1001	2.54 MB	30 Nov 2004
Audio: Intel® HD Audio Controller - Realtek codec	5.10.0.5034	40.9 MB	30 Nov 2004
LAN: Marvell* Yukon*-EC Gigabit Ethernet Adapter Software	7.24.1.3	7.51 MB	2 Dec 2004
RAID: Intel Application Accelerator	4.6.0.6758	15.1 MB	8 Dec 2004
RAID: F6 Driver Disk (Optional)	4.6.0.6758	316 KB	8 Dec 2004
TPM: Infineon* Trusted Platform Module Driver	1.70.154.1	3.18 MB	7 Dec 2004

Check if Win 2k supports TPM

Windows XP* Drivers

INF: Intel® Chipset Software Installation Utility	6.2.1.1001	2.54 MB	30 Nov 2004
Audio: Intel® HD Audio Controller - Realtek codec	5.10.0.5034	40.9 MB	30 Nov 2004
LAN: Marvell* Yukon*-EC Gigabit Ethernet Adapter Software	7.24.1.3	7.51 MB	2 Dec 2004
RAID: Intel Application Accelerator	4.6.0.6758	15.1 MB	8 Dec 2004
RAID: F6 Driver Disk (Optional)	4.6.0.6758	316 KB	8 Dec 2004
TPM: Infineon* Trusted Platform Module Driver	1.70.154.1	3.18 MB	7 Dec 2004

Note:- All the above drivers are PC99 certified.