

Vig690M Motherboard Manual

Viglen

**Great
Minds
Think**

viglen

Viglen, EMC and the 'CE' mark

CE Marking

European standards are being harmonised across borders. If products comply with the same standards in all European countries, product exporting and importing is made simple - paving our way to a common market. If you buy a product with a 'CE' mark on it (shown below), on the box, in the manual, or on the guarantee - it complies with the currently enforced directive(s).



Introduction to EMC

EMC (Electromagnetic Compatibility) is the term used to describe certain issues with RF (Radio Frequency) energy. Electrical items should be designed so they do not interfere with each other through RF emissions. E.g. If you turn on your microwave, your television shouldn't display interference if both items are CE marked to the EMC directive.

If emitted RF energy is not kept low, it can interfere with other electrical circuitry - E.g. Cars Automatic Braking Systems have been known to activate by themselves while in a strong RF field. As this has obvious repercussions ALL electrical products likely to cause RF related problems have to be 'CE' marked from 1st January 1996 onwards.

If a product conforms to the EMC directive, not only should its RF emissions be very low, but its immunity to RF energy (and other types) should be high. The apparatus has to resist many 'real world' phenomena such as static shocks and mains voltage transients.

Viglen's Environment laboratory

To gain a 'CE' mark, the Viglen computer range has had to undergo many difficult tests to ensure it is Electromagnetically Compatible. These are carried out in the in-house 'Environment lab' at Viglen Headquarters. We have made every effort to guarantee that each computer leaving our factory complies fully with the correct standards. To ensure the computer system maintains compliance throughout its functional life, it is essential you follow these guidelines.

- Install the system according to Viglen's instructions
- If you open up your Viglen:
 - Keep internal cabling in place as supplied.
 - Ensure the lid is tightly secured afterwards
 - Do not remove drive bay shields unless installing a 'CE' marked peripheral in its place
 - The clips or 'bumps' around the lips of the case increase conductivity - do not remove or damage.
 - Do not remove the ferrite ring from the L.E.D cables.
 - Only use your Viglen computer with 'CE' marked peripherals

This system has been tested in accordance with European standards for use in residential and light industrial areas - this specifies a 10 meter testing radius for emissions and immunity. If you do experience any adverse affects which you think might be related to your computer, try moving it at least 10 meters away from the affected item. If you still experience problems, contact Viglen's Technical Support department who will put you straight through to an EMC engineer - s/he will do everything possible to help. If modifications are made to your Viglen computer system, it might breach EMC regulations. Viglen take no responsibility (with regards to EMC characteristics) of equipment which has been tampered with or modified.



This symbol on the product or on its packaging indicates that the product shall not be treated as household waste. Instead it shall be handed over to the applicable collection point for recycling of electrical and electronic equipment. By ensuring this product is disposed of correctly, you will help prevent potential negative consequences for the environment and human health, which could otherwise be caused by inappropriate waste handling of this product. The recycling of materials will help to conserve natural resources. For more detailed information about recycling of this product, please contact your local city office, your household waste disposal service or Viglen Ltd.

Copyrights and Trademarks

Please note

The material in this manual is subject to change without notice.

Trademarks

Microsoft, Windows XP Pro, Windows Vista, Windows 7, Windows 8/8.1 and MS-DOS are registered trademarks of Microsoft Corporation. IBM PC, XT, AT and PS/2 are trademarks of International Business Machines Corporation. Core i3/i5/i7™ and Pentium® are registered trademarks of Intel® Corporation. All other trademarks are acknowledged. Genie, Vig, Viglen, and Omnino are trademarks of Viglen Limited.

Copyright and Patents

This manual and all accompanying software and documentation are copyrighted and all rights reserved. This product, including software and documentation, may not, in whole or in part, be copied, photocopied, translated or reduced to any electronic or machine-readable form, without prior written consent except for copies retained by the purchaser for backup.

© Copyright 2013 Viglen Limited
All Rights Reserved
Vig690M Manual Version 1.0
Printed in the United Kingdom

Liability

No warranty or representation, either expressed or implied, is made with respect to this documentation, its quality, performance, merchantability or fitness for a particular purpose. As a result the documentation is licensed as is, and you, the licensee, are assuming the entire risk as to its quality and performance. The vendor reserves the right to revise this operation manual and all accompanying software and documentation and to make changes in the content without obligation to notify any person or organisation of the revision or change.

In no event will the vendor be liable for direct, indirect, special, incidental or consequential damages arising out of the use or inability to use this product or documentation, even if advised of the possibility of such damages. In particular, the vendor shall not have liability for any hardware, software or data stored or used with the product, including the costs of repairing, replacing or recovering such hardware, software or data.

Contents

Chapter 1: Motherboard Overview	4
Introduction	4
Feature Summary	5
System Board Components	14
Back Panel Connectors	15
Chapter 2: System Board Options	16
Before You Begin/ Steps to Prevent Static Discharge	17
Overview of Jumper Settings	17
System Board Jumper Settings	18
Motherboard Connectors	19
Upgrading the CPU	25
Installing & Removing Memory Modules	29
Replacing the Clock/CMOS RAM Battery	31
Chapter 3: Solving Problems	32
Resetting the System	32
Troubleshooting Procedures	33
Problems & Suggestions	34
Chapter 4: System BIOS	36
What is the BIOS?	36
The Power-On Sequence	36
BIOS Upgrades	37
Using AFUDE238 to Update the BIOS	37
BIOS Setup	38
Configure system with Windows 8/8.1	42
Restoring Defaults and Saving Changes	44
Chapter 5: Suggestions	47

Chapter 1: Motherboard Overview

Introduction

This manual describes the Viglen Vig690M motherboard inside your computer. The motherboard is the most important part of your computer. It contains the CPU, memory and graphics circuitry that make the computer work in the correct manner.

The Vig690M motherboard is a Micro-ATX form factor offering legacy to premium features. PS/2 mouse and keyboard ports, integrated Graphics via VGA and DVI, High Definition Audio via 3 flexible audio jacks and integrated 10/100/1000 network connection, as well as 4 USB 2.0 and 2 USB 3.0 ports to enrich your multimedia creation experience.

The Vig690M supports 4th generation Intel Core i3, i5, i7, Pentium and Celeron processors, as well as being Microsoft Windows 8 WHQL certified.

This manual contains technical information about the Viglen Vig690M motherboard and other hardware components inside your computer. If you are new to computers we recommend that you read the user guide first. If you are an experienced computer user this manual should provide all the information you will need to perform simple upgrades and maintenance.

We hope that this manual is both readable and informative. If you have any comments for suggestions about how we could improve the format then please fill out the form at the back of the manual and send it to us.

Above all we hope that you enjoy using your Viglen computer.

Feature Summary

Form factor:

- Micro-ATX Form Factor: 22.6 cm X 17.3 cm

Processor:

- Supports 4th generation Intel® Core™ i7, Intel® Core™ i5, Intel® Core™ i3, Intel® Pentium® and Celeron® processors in an LGA1150 socket.
- Integrated graphics processing (processors with Intel® Graphics Technology)
- External graphics interface controller
- Integrated memory controller

Chipset

- Intel® H81 Express Chipset

Memory

- Support for 2 x DDR3-1066/1333/1600MHz DIMMs.
- Up to 16GB total
- Supports Dual-Channel mode

Graphics

- Integrated graphics support for processors with Intel Graphics Technology:
 - VGA
 - DVI-D

Audio

- Realtek® ALC887 HD Audio compatible subsystem
- Flexible 8-channel audio with jack sensing
- Compliant with Azalia 1.0 Spec

LAN

- Gigabit (10/100/1000 Mbits/s) LAN subsystem using the Realtek® RTL8111G Gigabit Ethernet Controller

SATA

- 2 x SATA 6Gb/s ports (SATA1 & SATA2)
- 2 x SATA 3Gb/s ports (SATA3 & SATA4)

Internal Connectors

- ATX 24-pin power connector
- 4-pin ATX 12V power connector
- 1x CPU fan connector
- 2x system fan connectors
- Front panel audio connector
- Front panel connector
- 1x chassis intrusion connector
- 2x USB 2.0 connectors (providing connectivity for 4 devices)
- 1x Clear CMOS header
- 1x Serial header
- 2x USB power
- 1x TPM module connector (Optional TPM Module)

Expansion Capabilities

- 1 x PCI Express 2.0 x16 slot
- 1 x PCI Express 2.0 x1 slot

Rear I/O Ports

- 1x PS/2 mouse port
- 1x PS/2 keyboard port
- 4x USB 2.0 ports
- 2x USB 3.0 ports
- 1x DVI port*, supporting a maximum resolution of 1920x1200
- 1x VGA port*, supporting a maximum resolution of 1920x1200
- 1x RJ-45 LAN port
- 3x flexible audio jacks (Line In ,Line Out, Microphone)*

*(To reach the 8-channel sound effect, the 7th and 8th channels must be outputted from front panel.

Processor

The motherboard is designed to support the Intel Core i7, Intel Core i5, Intel Core i3, and Intel Pentium processors in an LGA1150 socket.

Other processors may be supported in the future. This board is designed to support processors with a maximum TDP of 84 W.

Chipset

The Intel H81 Express Chipset consisting of the Intel H81 Platform Controller Hub (PCH) provides interfaces to the processor, USB, SATA, LPC, audio, network, display, and PCI Express. The PCH is a centralized controller for the board's I/O paths.

Memory

The motherboard has two DDR3 DIMM sockets and supports the following memory features:

- Two independent memory channels with interleaved mode support
- Supports 1.2 V – 1.8 V DIMM memory voltage
- Support for non-ECC, unbuffered, single-sided or double-sided DIMMs with x8 organization
- 16 GB maximum total system memory (with 8GB memory technology).
- Minimum total system memory: 1GB using 1GB x8 module
- Serial Presence Detect
- DDR3 1600MHz, DDR3 1333MHz and DDR3 1066MHz SDRAM DIMMs

NOTE: *To be fully compliant with all applicable DDR SDRAM memory specifications, the board should be populated with DIMMs that support the Serial Presence Detect (SPD) data structure. This allows the BIOS to read the SPD data and program the chipset to accurately configure memory settings for optimum performance. If non-SPD memory is installed, the BIOS will attempt to correctly configure the memory settings, but performance and reliability may be impacted or the DIMMs may not function under the determined frequency.*

Memory Configurations

The Intel Core i7, Intel Core i5, Intel Core i3, and Intel Pentium processors support the following types of memory organization:

- **Dual channel (Interleaved) mode.** This mode offers the highest throughput for real world applications. Dual channel mode is enabled when the installed memory capacities of both DIMM channels are equal. Technology and device width can vary from one channel to the other but the installed memory capacity for each channel must be equal. If different DIMM speeds are used between channels, the slowest memory timing will be used.
- **Single channel (Asymmetric) mode.** This mode is equivalent to single channel bandwidth operation for real world applications. This mode is used when only a single DIMM is installed or the memory capacities are unequal. Technology and device

width can vary from one channel to the other. If different DIMM speeds are used between channels, the slowest memory timing will be used.

Graphics Subsystem

The board supports system graphics through either Intel Graphics Technology or a PCI Express x16 add-in graphics card.

Integrated Graphics

The board supports integrated graphics through the Intel® Flexible Display Interface (Intel® FDI) for processors with Intel Graphics Technology.

Analog Display (VGA)

The VGA port supports analog displays. The maximum supported resolution is 1920 x 1200 at 60Hz refresh rate. The VGA port is enabled for POST whenever a monitor is attached, regardless of the DVI-D connector status.

DVI-D

The maximum supported resolution is 1920 x 1200 at 60Hz refresh rate.

PCI Express x16 Graphics

The Intel Core i7/i5/i3, Pentium and Celeron processors in the LGA1150 socket support discrete add in graphics cards through the PCI Express 2.0 x16 connector:

- Supports PCI Express GEN3 frequency of 2.5 GHz resulting in 8.0 Gb/s each direction (1000 MB/s) per lane. Maximum theoretical bandwidth on interface is 16GB/s in each direction, simultaneously, when operating in x16 mode.
- Supports PCI Express GEN2 frequency of 2.5 GHz resulting in 5.0 Gb/s each direction (500 MB/s) per lane. Maximum theoretical bandwidth on interface is 8GB/s in each direction, simultaneously, when operating in x16 mode.
- Supports PCI Express GEN1 frequency of 1.25 GHz resulting in 2.5 Gb/s each direction (250 MB/s) per lane. Maximum theoretical bandwidth on interface is 4GB/s in each direction, simultaneously, when operating in x16 mode.

Audio Subsystem

The motherboard supports Intel High Definition Audio through a Realtek ACL887 audio codec. The following software features are supported

- Meets Microsoft WLP 3.x and future WLP audio requirements
- WaveRT-based audio function driver for Windows Vista and Windows 7
- EAX™ 1.0 and 2.0 compatible
- Direct Sound 3D™ compatible
- I3DL2 compatible
- Emulation of 26 sound environments to enhance gaming experience
- Multi bands of software equalizer and tool are provided
- Voice Cancellation and Key Shifting effect
- Dynamic range control (expander, compressor and limiter) with adjustable parameters
- Smart multiple streaming operation

These audio connectors are used for audio devices. It is easy to differentiate between audio effects according to the colour of audio jacks.



Figure 1: Audio Connectors

- Line-In (Blue) - Line In, is used for external CD player, tape-player or other audio devices.
- Line-Out (Green) - Line Out, is a connector for speakers or headphones.
- Mic (Pink) - Mic, is a connector for microphones.

Notes: *If you want to reach the 8-channel sound effect, the 7th and 8th channels must be output from front panel.*

LAN Subsystem

The LAN subsystem consists of the following:

- Realtek RTL8111G Gigabit Ethernet Controller (10/100/1000Mbps/s)
- RJ-45 LAN connector with integrated status LEDs

Additional features of the LAN subsystem include:

- Integrated 10/100/1000 transceiver
- Crossover Detection & Auto-Correction
- Wake-on-LAN and remote wake-up support
- Supports Full Duplex flow control (IEEE 802.3x)
- Supports jumbo frame to 9K bytes
- Fully compliant with IEEE 802.3, IEEE 802.3u, IEEE 802.3ab
- Supports power down/link down power saving

RJ-45 LAN Connector LEDs

The two LEDs are built into the RJ-45 LAN connector located on the back panel. These LEDs indicate the status of the LAN as shown in Table 1.

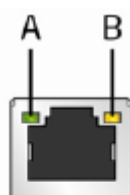

Item	Description
A	Link/Activity LED (green)
B	Link Speed LED (green/yellow)

Figure 2: LAN Connector LED Locations

Table 1: LAN LED Status

LED	Color	LED State	Condition
Left	Yellow	Off	LAN link is not established.
		On(Steady state)	LAN link is established.
		On(brighter & pulsing)	The computer is communicating with another computer on the LAN.
Right	Green	Off	10 Mbit/sec data rate is selected.
		On	100 Mbit/sec data rate is selected.
	Orange	On	1000 Mbit/sec data rate is selected.

Universal Serial Bus (USB)

The motherboard supports up to 8 USB 2.0 ports and 2 USB 3.0. The port arrangement is as follows:

- Four USB 2.0 ports are implemented with stacked back panel connectors (black)
- Two USB 3.0 ports are implemented with stacked back panel connectors (blue)
- Four USB 2.0 front panel ports are implemented through two dual-port internal headers

All USB ports are high-speed, full-speed, and low-speed capable.

NOTE: Computer systems that have an unshielded cable attached to a USB port may not meet FCC Class B requirements, even if no device or a low-speed (sub-channel) USB device is attached to the cable. Use shielded cable that meets the requirements for high-speed (fully rated) devices.

SATA Support

The board provides two 6 Gb/s and two 3 Gb/s SATA connectors, which support one device per connector.

NOTE: By default the SATA mode is set to AHCI in the BIOS to improve system performance. During Microsoft Windows XP installation, you must press F6 to install the AHCI drivers. Microsoft Windows Vista, Windows 7 and Windows 8 include the necessary RAID drivers for both AHCI and RAID without the need to install separate RAID drivers using the F6 switch in the operating system installation process. It is advised to install the latest AHCI drivers to improve system performance.

Expansion Slots

The motherboard provides the following expansion capability:

- One PCI Express 2.0 x16 slot
- One PCI Express 2.0 x1 slot

Legacy I/O Controller

The Legacy I/O Controller provides the following features:

- One serial port header
- PS/2-style keyboard/mouse interface on the back panel
- Serial IRQ interface compatible with serialized IRQ support for PCI Conventional bus systems
- Intelligent power management, including a programmable wake-up event interface
- Conventional PCI bus power management support

The BIOS Setup program provides configuration options for the Legacy I/O controller.

Real-Time Clock, CMOS RAM, and Battery

A coin-cell battery (CR2032) powers the real-time clock and CMOS memory. When the computer is not plugged into a wall socket, the battery has an estimated life of three years. When the computer is plugged in, the standby current from the power supply extends the life of the battery.

The clock is accurate to ± 13 minutes/year at 25 °C with power applied through the power supply 5V STBY rail.

NOTE: *If the battery and AC power fail, date and time values will be reset and the user will be notified during POST. When the voltage drops below a certain level, the BIOS Setup program settings stored in CMOS RAM (for example, the date and time) might not be accurate. Replace the battery with an equivalent one.*

BIOS

The BIOS provides the Power-On Self-Test (POST), the BIOS Setup program, and the PCI/PCI Express and SATA auto-configuration utilities. The BIOS is stored in the Serial Peripheral Interface (SPI) Flash memory device.

SATA Auto Configuration

If you install a SATA device (such as a hard disk drive) in your computer, the auto-configuration utility in the BIOS automatically detects and configures the device for your computer. You do not need to run the BIOS Setup program after installing a SATA device. You can override the auto-configuration options by specifying manual configuration in the BIOS Setup program.

PCI/PCI Express Auto Configuration

If you install a PCI Express add-in card in your computer, the PCI/PCI Express auto-configuration utility in the BIOS automatically detects and configures the resources (IRQs, DMA channels, and I/O space) for that add-in card. You do not need to run the BIOS Setup program after you install a Conventional PCI or PCI Express add-in card.

BIOS Security Passwords

The BIOS includes security features that restrict whether the BIOS Setup program can be accessed and who can boot the computer. An administrator password and a user password can be set for the BIOS Setup and for booting the computer, with the following restrictions:

- The administrator password gives unrestricted access to view and change all Setup options. If only the administrator password is set, pressing <Enter> at the password prompt of Setup gives the user restricted access to Setup.
- If both the administrator and user passwords are set, you must enter either the administrator password or the user password to access Setup. Setup options are then

available for viewing and changing depending on whether the administrator or user password was entered.

- Setting a user password restricts who can boot the computer. The password prompt is displayed before the computer is booted. If only the administrator password is set, the computer boots without asking for a password. If both passwords are set, you can enter either password to boot the computer.

System Board Components

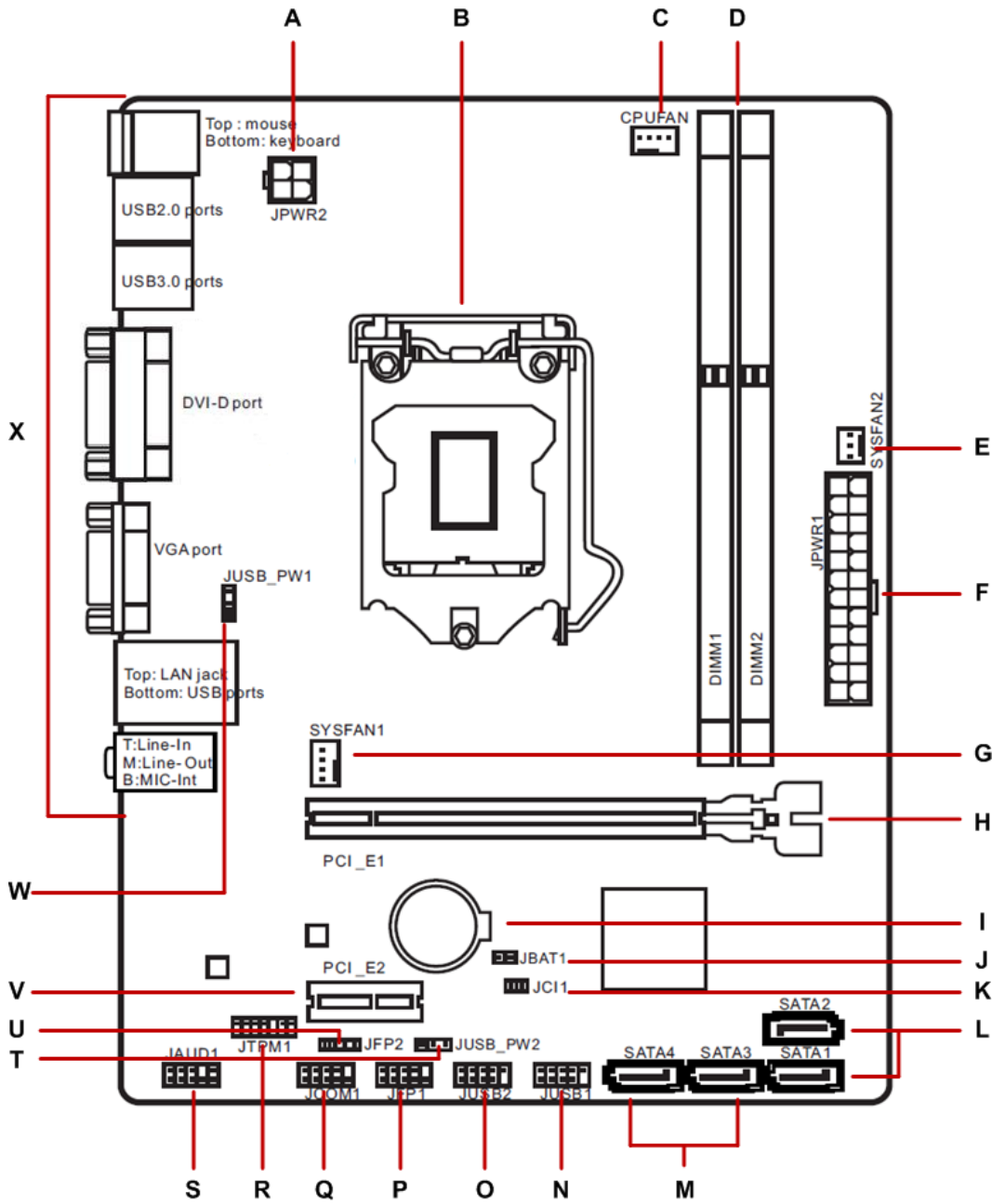

Figure 3: Motherboard Layout & Components

Table 2: Motherboard Connection

A	4-pin Power Socket Connector	M	SATA1 & SATA2 Ports (3Gb/s)
B	CPU Socket	N	USB Header 1
C	CPU Fan Header	O	USB Header 2
D	DIMM Sockets	P	Front Panel Header
E	System Fan Header 2	Q	Serial Port Header
F	24-pin Power Socket Connector	R	TPM Header
G	System Fan Header 1	S	Front Panel Audio Header
H	PCI Express x16 Slot	T	USB power Jumper 2
I	Battery	U	Front Panel Header 2
J	JBAT_1 Clear CMOS Header	V	PCI Express x1 Slot
K	Chassis Intrusion Header	W	USB power Jumper 1
L	SATA1 & SATA2 Ports (6Gb/s)	X	Back Panel Connectors

Back Panel Connectors

The motherboard external IO connectors are attached to a metallic I/O shield. This shield serves several purposes:

- It protects the sensitive motherboard from any external EMC interference.
- It stops the computer from interfering with other electrical devices.
- It allows the motherboard to be easily upgraded in the future without having to resort to buying a whole new case. Simply change the I/O shield to match the motherboard.

The I/O shield provides external access to PS/2 mouse/keyboard connectors as well as the USB ports, LAN Port, audio connectors, VGA and DVI-D ports.

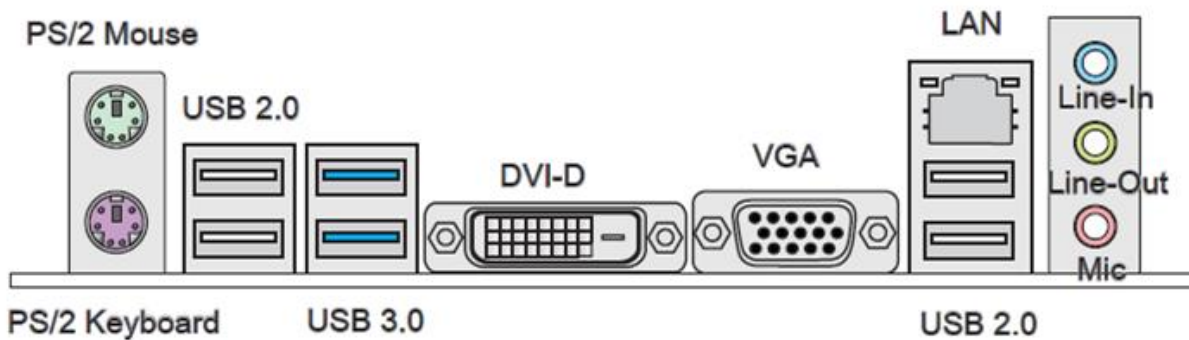

Figure 4: Back Panel Connectors

- **Mouse/Keyboard** - The standard PS/2® mouse/keyboard DIN connector is for a PS/2® mouse/keyboard.
- **USB 2.0 Ports** - The USB 2.0 ports are used for attaching USB devices such as keyboard, mouse, or other USB compatible devices.
- **USB 3.0 Ports** - The USB 3.0 ports are used for attaching USB devices such as keyboard, mouse, or other USB compatible devices.
- **VGA Port** - The DB15-pin female connector is provided for monitor.
- **DVI-D Port** - Port used for connecting to monitors.
- **LAN Port** - The standard RJ-45 LAN jack is for connection to the Local Area Network (LAN). You can connect a network cable to it.
- **Audio Ports** - These audio connectors are used for audio devices.

Chapter 2: System Board Options

The Vig690M motherboard is supports Intel® Core i3, i5, i7, Pentium and Celeron processors in the LGA1150 socket. RAM can be upgraded to a maximum of 16GB using DDR3 1066, 1333 or 1600MHz Non ECC Unbuffered DIMMs.

WARNING!

Unplug the system before carrying out the procedures described in this chapter. Failure to disconnect power before you open the system can result in personal injury or equipment damage. Hazardous voltage, current, and energy levels are present in this product. Power switch terminals can have hazardous Voltages present even when the power switch is off.

The procedures assume familiarity with the general terminology associated with personal computers and with the safety practices and regulatory compliance required for using and modifying electronic equipment.

Do not operate the system with the cover removed. Always replace the cover before turning on the system.

As the colours of the wires in the mains lead of this computer may not correspond with the coloured markings identifying the terminals in your plug precede as follows:

The wire which is coloured **green-and-yellow** must be **connected** to the **terminal** in the plug which is marked by the letter **E** or by the safety Earth symbol **Q** or coloured green or **green-and-yellow**.

The wire which is coloured blue must be connected to the terminal which is marked with the letter **N** or coloured **black**.

The wire which is coloured brown must be connected to the terminal which is marked with the letter **L** or coloured **red**.

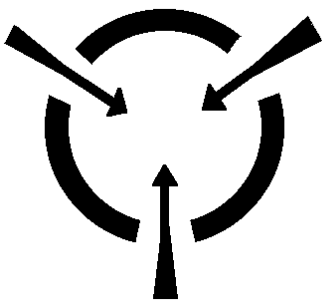

CAUTION!

The Viglen Vig690M motherboard and associated components are sensitive electronic devices. A small static shock from your body can cause expensive damage to your equipment.

BEFORE YOU BEGIN

Make sure you are earthed and free of static charge before you open the computer case. If you are unsure about upgrading your computer, return it to Viglen so a qualified engineer can perform the upgrade.

STEPS TO TAKE TO PREVENT STATIC DISCHARGE:

1. The best way to prevent static discharge is to buy an anti-static strap from your local electrical shop. While you are wearing the strap and it is earthed, static charge will be harmlessly bled to ground.
2. Do not remove the component from its anti-static protective packaging until you are about to install it.
3. Hold boards by the edges - try not to touch components / interface strips etc.

NOTE: *We recommend that you return your computer to the service department for upgrading. Any work carried out is fully guaranteed. Upgrades should only be carried out by persons who are familiar with handling IC's, as incorrect installation will invalidate the guarantee.*

Overview of Jumper Settings

The Vig690M motherboard contains the latest technology to offer an almost jumperless configuration. All Intel® Core CPUs are automatically detected and the speed is automatically set from the information provided by the CPU.

The only jumpers present on the motherboard are for clearing all the CMOS settings and controlling power options for the USB ports. In the unlikely event of the CMOS becoming corrupted then jumper JBAT1 can be set to clear the contents of the CMOS, and for write protecting the BIOS.

CAUTION!

Never remove jumpers using large pliers as this can damage the pins. The best way to remove a jumper is to use a small pair of tweezers or fine needle-nosed pliers.

Never remove a jumper when the computer is switch on. Always switch the computer off first.

System Board Jumper Settings

CAUTION

Do not move the jumper with the power on. Always turn off the power and unplug the power cord from the computer before changing a jumper setting. Otherwise, the board could be damaged.

- **Clear CMOS Jumper: JBAT1**

The configuration Jumper (JBAT1) allows the user to clear the CMOS. The CMOS RAM onboard has a power supply from an external battery to keep the data of the system configuration. The CMOS RAM allows the system to automatically boot the OS every time it is turned on.

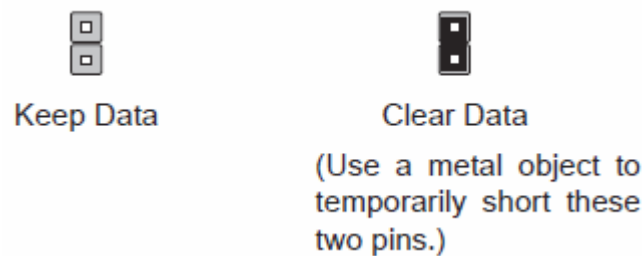

Figure 5: Clear CMOS jumper

- **USB power Jumper: JUSB_PW1 & JUSB_PW2**

This jumper allows you to enable/ disable the “Wakeup from S3/S4/S5 by USB and PS/2 device” function.

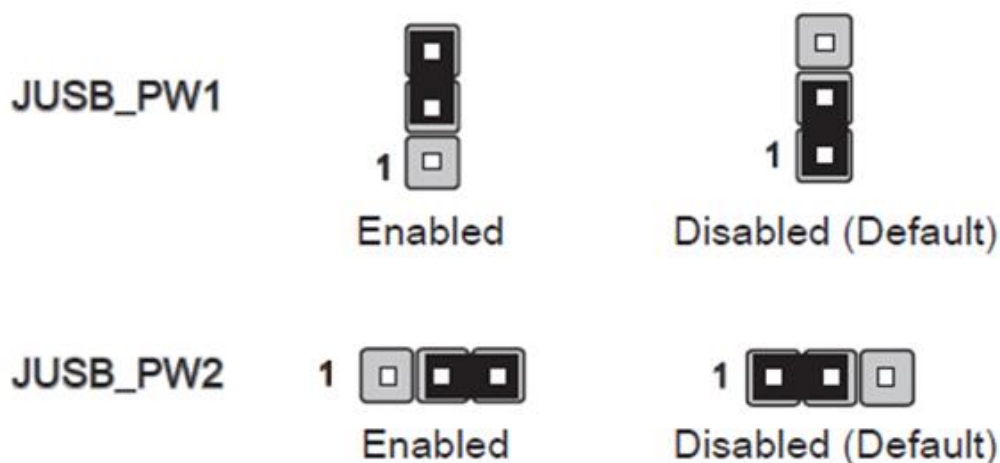

Figure 6: USB power Jumper

Motherboard Connectors

There are connectors on the motherboard for the Power supply, HD audio, fans, front panel audio, front panel USB and front panel connectors. The location and/or details of these connections are shown below.

Power Connectors

- **ATX 24-Pin Power Connector: JPWR1**

This connector allows you to connect an ATX 12V 24-pin power supply. To connect the ATX 24-pin power supply, make sure the plug of the power supply is inserted in the proper orientation and the pins are aligned. Then push down the power supply firmly into the connector.

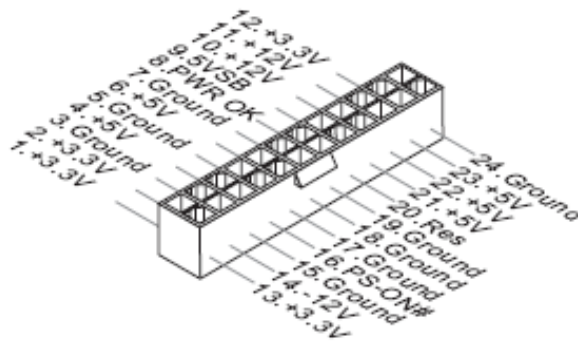

Figure 7: ATX 24-Pin Power Connector

- **ATX 4-Pin Power Connector: JPWR2**

This 12V power connector is used to provide power directly to the CPU voltage regulator and must be used. Failure to do so will prevent the motherboard from booting.

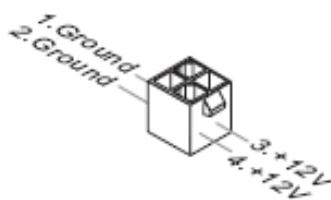

Figure 8: ATX 12V 4-PIN power connector

NOTE:

- *Make sure that all the connectors are connected to proper ATX power supplies to ensure stable operation of the Motherboard*
- *ATX 12V power connection should be greater than 18A.*
If a high power (75W or greater) add-in card is installed in the PCI Express connector, that card must be connected directly to the power supply. Failure to do so may cause damage to the motherboard and the add-in card.

- **Front Panel Connectors: JFP1, JFP2:**

These connectors are for electrical connection to the front panel switches and LEDs. The JFP1 is compliant with Intel® Front Panel I/O Connectivity Design Guide.

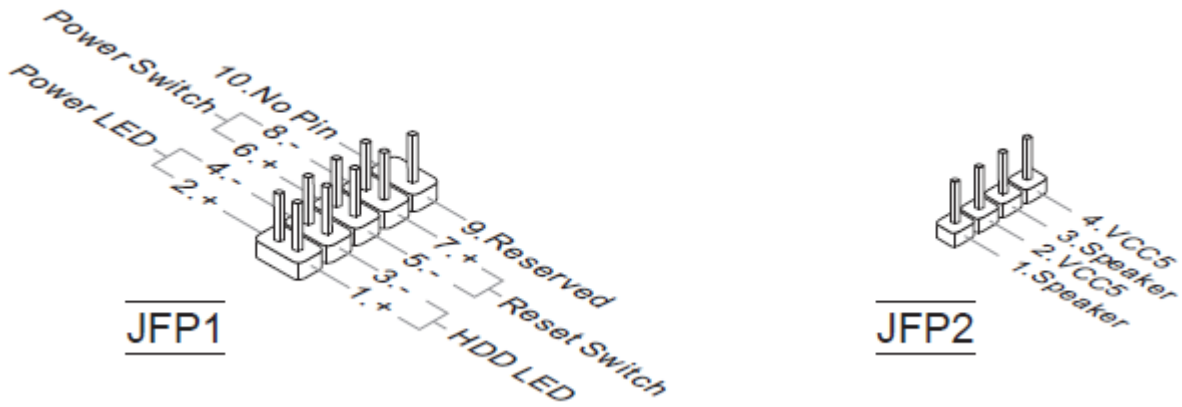

Figure 9: Front Panel Connectors

Table 3: Front Panel Connectors (JFP1)

Pin	Connector	Comments
1-3	Hard Drive Activity LED Header	Pins 1 and 3 can be connected to an LED to provide a visual indicator that data is being read from or written to a hard drive. Proper LED function requires a Serial ATA hard drive connected to an onboard Serial ATA connector.
5-7	Reset Switch Header	Pins 5 and 7 can be connected to a momentary single pole, single throw (SPST) type switch that is normally open. When the switch is closed, the board resets and runs the POST.
2-4	Power/Sleep LED Header	Pins 2 and 4 can be connected to a one- or two-colour LED. This display if the computer is active or not.
6-8	Power Switch Header	Pins 6 and 8 can be connected to a front panel momentary-contact power switch. The switch must pull the SW_ON# pin to ground for at least 50 ms to signal the power supply to switch on or off. (The time requirement is due to internal debounce circuitry on the board.) At least two seconds must pass before the power supply will recognize another on/off signal.

- **Front Panel Audio Connector: JAUD1**

This connector allows you to connect the front panel audio and is compliant with Intel® Front Panel I/O Connectivity Design Guide.

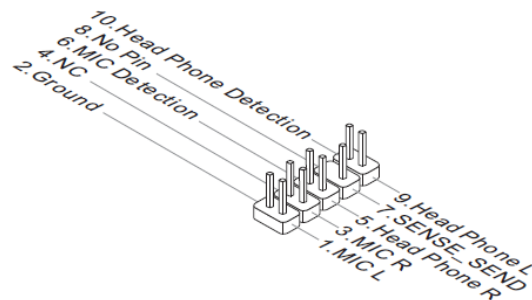

Figure 10: Front panel audio connector

- **Front USB Connector: JUSB1, JUSB2**

This connector, compliant with Intel® I/O Connectivity Design Guide, is ideal for connecting high-speed USB interface peripherals such as USB HDD, digital cameras, MP3 players, printers, modems and the like.

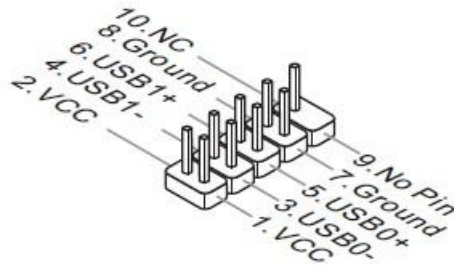

Figure 11: Front USB connectors

- **JCI1 : Chassis Intrusion Connector**

This connector connects to the chassis intrusion switch cable. If the computer case is opened, the chassis intrusion mechanism will be activated. The system will record this intrusion and a warning message will flash on screen. To clear the warning, you must enter the BIO S utility and clear the record.

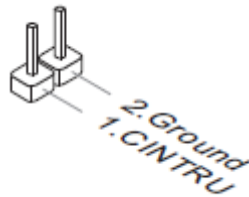

Figure 12: Chassis Intrusion connector

- **TPM Module connector: JTPM1**

This connector connects to a TPM (Trusted Platform Module) module (optional).

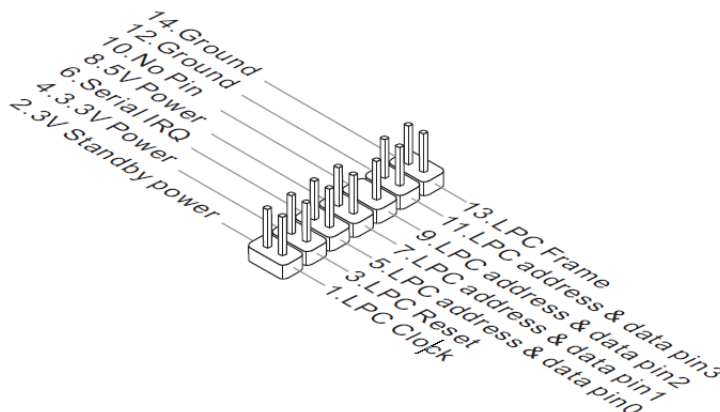

Figure 13: TPM Connector

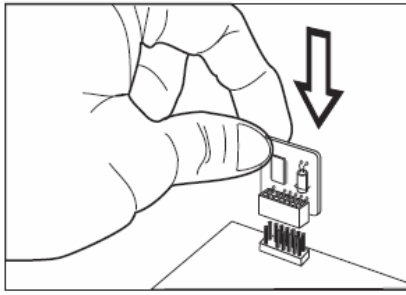

Figure 14: TPM Module

Fan Power Connectors: CPUFAN, SYSFAN1~2

The fan power connectors support system cooling fans with +12V. If the mainboard has a System Hardware Monitor chipset on-board, you must use a specially designed fan with a speed sensor to take advantage of the CPU fan control. Remember to connect all system fans. Some system fans may not connect to the mainboard and will instead connect to the power supply directly. A system fan can be plugged into any available system fan connector.

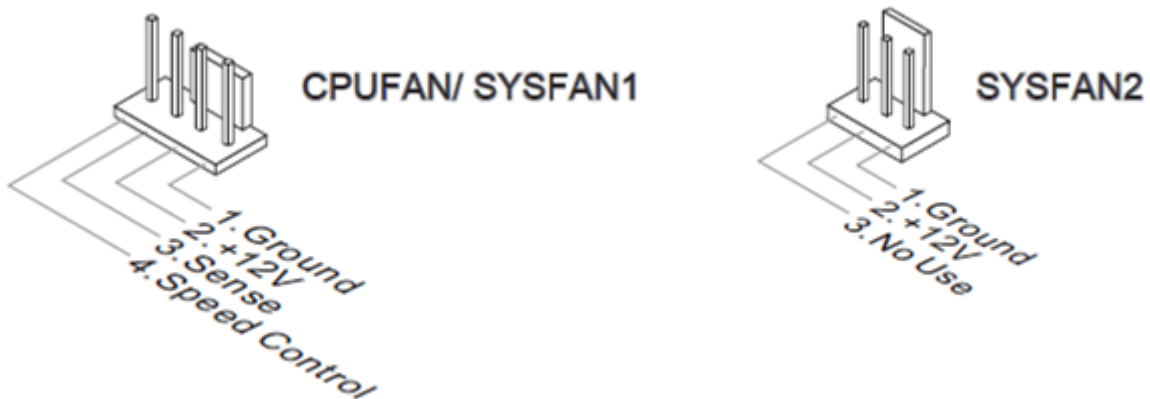

Figure 15: Fan Power connectors

- **Serial ATA Connector: SATA1 ~ SATA4**

This connector is a high-speed Serial ATA interface port. Each connector can connect to one Serial ATA device. Serial ATA devices include disk drives (HD), solid state drives (SSD), and optical drives (CD/ DVD/ Blu-Ray).

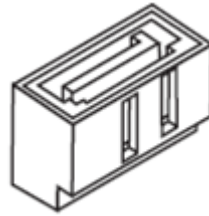

Figure 16: Serial ATA Connector

NOTE:

Please do not fold the serial ATA cable into 90-degree angle. Otherwise, data loss may occur during transmission.

- **Serial Port Header**

This connector is a 16550A high speed communication port that sends/receives 16 bytes FIFOs. You can attach a serial device.

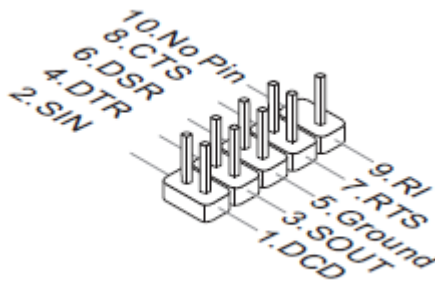

Figure 17: Serial Port Header

- **PCI Express Slot**

The PCI Express slot supports the PCI Express interface expansion card. The PCI Express x16 slot supports up to 4.0 GB/s transfer rate and the PCI Express x1 slot supports up to 250 MB/s

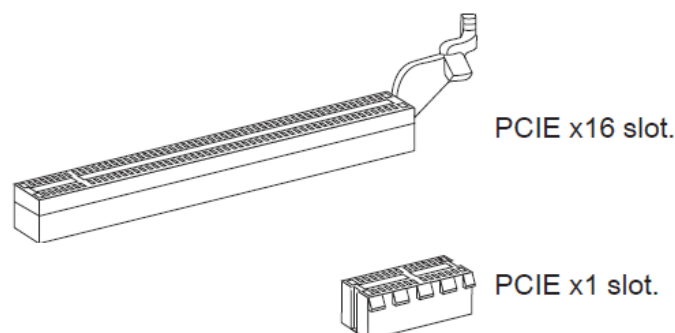

Figure 18: PCI Express Slots

Note: When adding or removing expansion cards, make sure that you unplug the power supply first.

- **PCI Express Slot**

IR Q, or interrupt request lines, are hardware lines over which devices can send interrupt requests to the processor. The PCI IR Q pins are typically connected to the PCI bus pins as followed:

Order Slot	1	2	3	4
PCI 1	INT E#	INT F#	INT G#	INT H#

Important

When adding or removing expansion cards, always turn off the power supply and unplug the power supply power cable from the power outlet. Read the expansion card's documentation to check for any necessary additional hardware or software changes.

Upgrading the CPU

CAUTION!

Before installing or removing a processor, make sure the AC power has been removed by unplugging the power cord from the computer; the standby power LED should not be lit. Failure to do so could damage the processor and the board.

To install a processor, follow these instructions:

1. Unlatch the processor socket lever by pushing it down and away from the socket. (Figure 19, A, B)

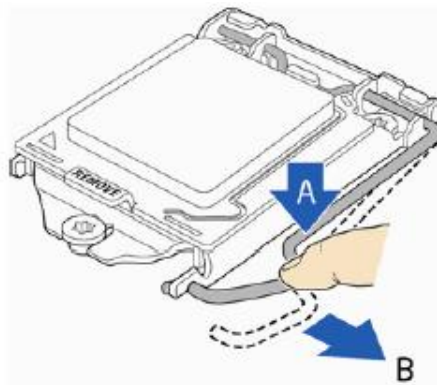

Figure 19: Unlatch the socket lever

2. Rotate the socket lever to lift the load plate away from the socket (Figure 20, A). Make sure that the load plate is in the fully open position (Figure 20, B) while being careful not to damage adjacent components. Do not touch the socket contacts.

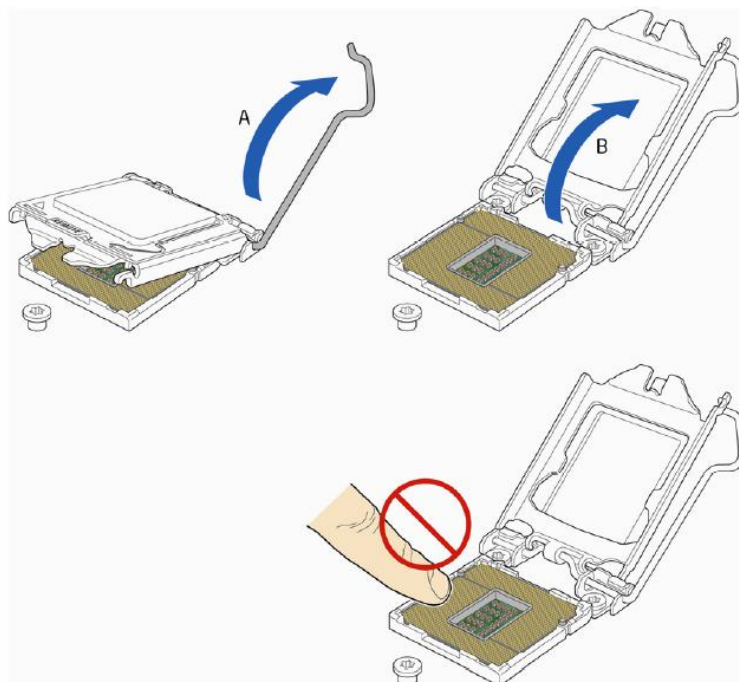

Figure 20: Lift the load plate

3. Remove the processor from its protective cover. Hold the processor only at the edges, being careful not to touch the bottom of the processor (see Figure 21).

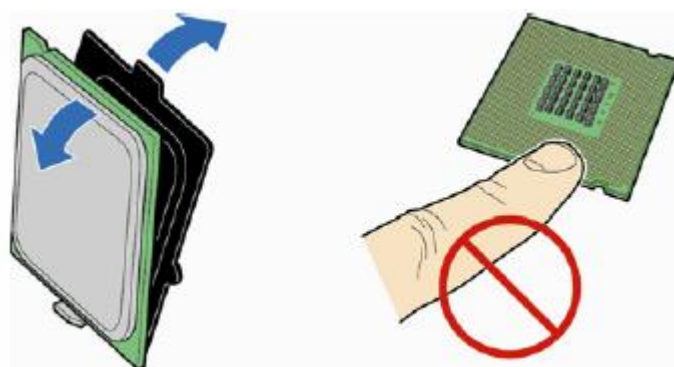

Figure 21: Remove the processor from the protective cover

Note: Do not discard the processor cover. Always replace the processor cover if you remove the processor from the socket.

4. Hold the processor with your thumb and index finger oriented as shown in Figure 22 to align your fingers with the socket finger cut-outs. Make sure that the processor Pin 1 indicator (gold triangle) is aligned with the Pin 1 chamfer on the socket (Figure 22, B) and that the notches on the processor align with the posts on the socket (Figure 22, C). Lower the processor straight down without tilting or sliding it in the socket (Figure 22, A).

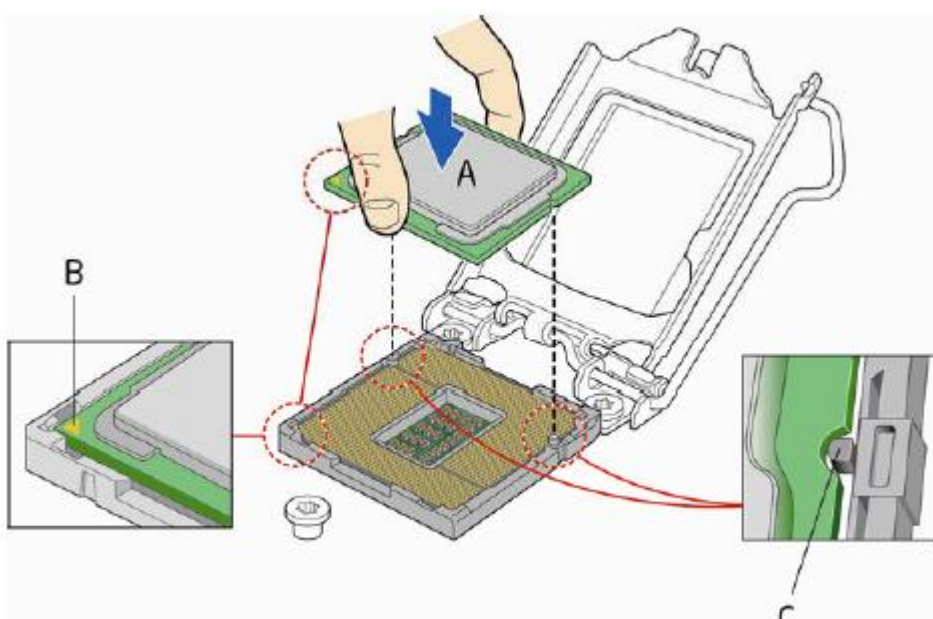

Figure 22: Install the processor

- Carefully lower the socket lever (Figure 23) while making sure that the front edge of the load plate slides under the shoulder screw cap as the lever is lowered. Latch the socket lever under the load plate tab (Figure 23, C, and D). The socket cover (Figure 23, B) will pop off as shown.

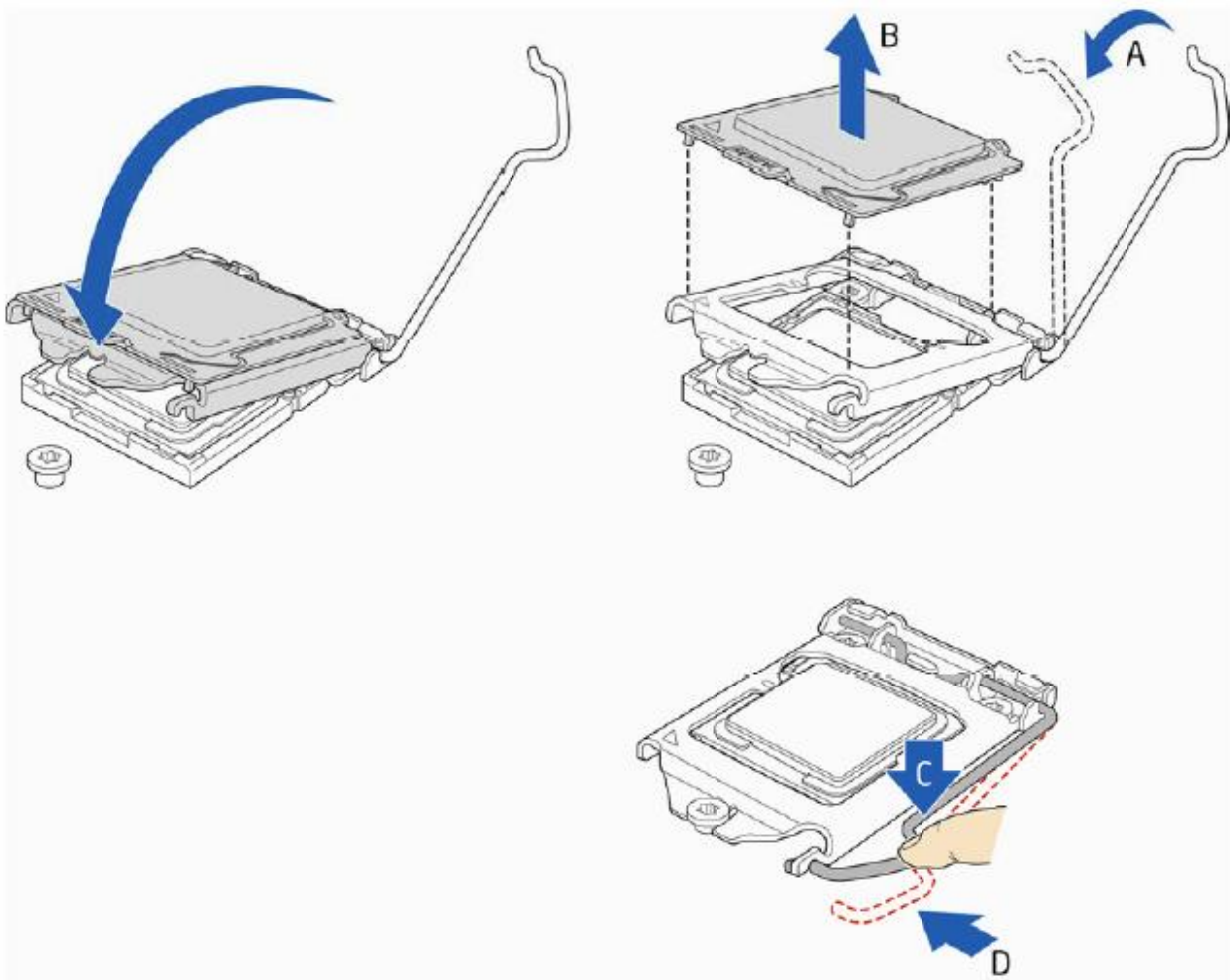

Figure 23: Secure the load plate in place

- Pick up the socket cover and remove it from the desktop board.

- **Connecting the Processor Fan Heat Sink Cable**

Connect the processor fan heat sink power cable to the 4-pin processor fan header (see Figure 24). A fan with a 4-pin connector as shown in Figure 24 is recommended.

1. Make sure the four hooks are in the proper position before you install the cooler.

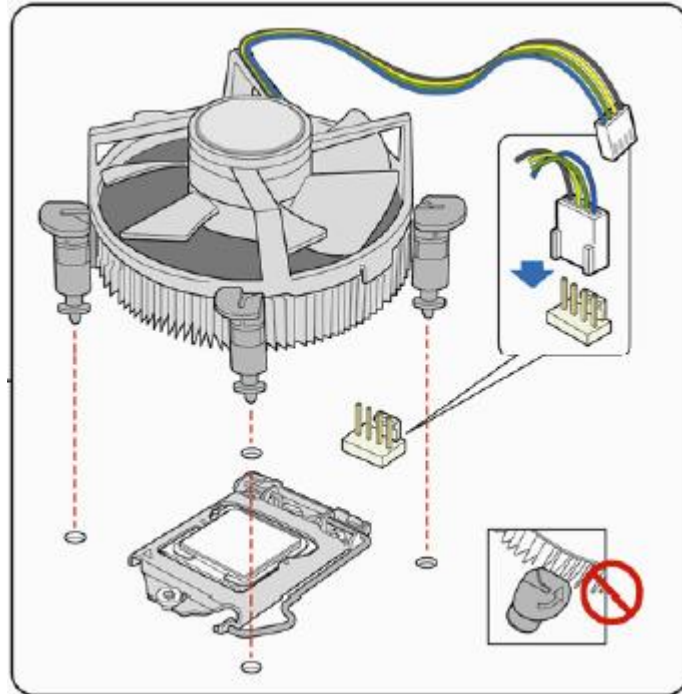

Figure 24: Connecting the processor fan heat sink power cable to the processor fan header

- **Removing the Processor**

For instructions on how to remove the processor fan heat sink and processor, refer to the processor installation manual.

Installing & Removing Memory Modules

• Installing Memory

You can install from 1GB to 16GB of memory in the motherboard DIMM sockets. The motherboard has two DIMM sockets. The motherboard supports the following memory features:

- Two DDR3 DIMMs with gold-plated contacts.
- Non-ECC (64-bit) memory.
- 1GB, 2GB, 4GB and 8GB modules.
- Memory Speeds 1066MHz, 1333MHz and 1600MHz

To install DIMMs, follow these steps:

1. Observe the precautions in “Before You Begin”. Turn off the computer and all Peripheral devices.
2. Remove the computer cover and locate the DIMM sockets.
3. Holding the DIMM by the edges, remove it from its antistatic package.
4. Make sure the clips at either end of the socket are pushed away from the socket.
5. Position the DIMM above the socket. Align the two small notches in the bottom edge of the DIMM with the keys in the socket. Insert the bottom edge of the DIMM into the socket.
6. When the DIMM is seated, push down on the top edge of the DIMM until the retaining clips at the ends of the socket snap into place. Make sure the clips are firmly in place.
7. Replace the computer cover.

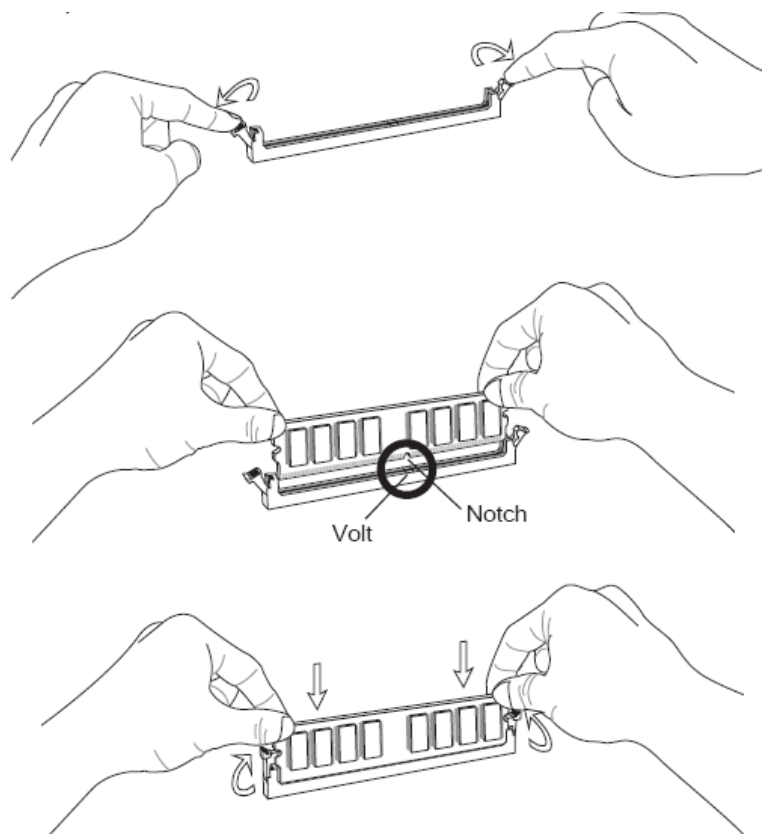

Figure 25: Memory Installation

Removing Memory

To remove a DIMM, follow these steps:

1. Observe the precautions in "Before You Begin".
2. Turn off all peripheral devices connected to the computer. Turn off the computer.
3. Remove the computer cover.
4. Gently spread the retaining clips at each end of the socket. The DIMM pops out of the socket. Hold the DIMM by the edges, lift it away from the socket, and store it in an antistatic package.
5. Reinstall and reconnect any parts you removed or disconnected to reach the DIMM sockets.

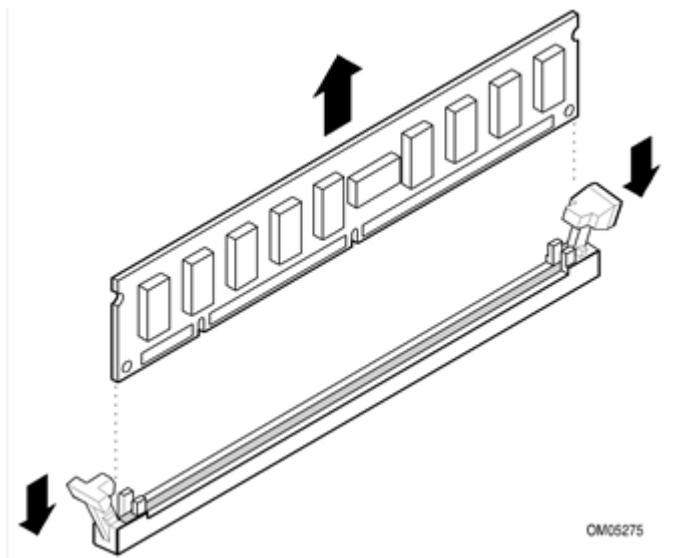

Figure 26: Removing Memory Modules

Replacing the Clock/CMOS RAM Battery

A lithium battery is installed in a socket on the system board.

The battery has an estimated life expectancy of seven years. When the battery starts to weaken, it loses voltage; when the voltage drops below a certain level, the system settings stored in CMOS RAM (for example, the date and time) may be wrong.

If the battery fails, you will need to replace it with a **CR2032** battery or an equivalent. As long as local ordinance permits, you may dispose of individual batteries as normal rubbish. Do not expose batteries to excessive heat or any naked flame. Keep all batteries away from children.

CAUTION!

Danger of explosion if the battery is incorrectly replaced. Replace only with the same or equivalent type recommended by Viglen. Discard used batteries according to manufacturer's instructions.

To replace the battery, carry out the following:

1. Observe the precautions in "Before You Begin."
2. Turn off all peripheral devices connected to the system.
3. Turn off the system.
4. Remove any components that are blocking access to the battery.
5. Figure 27 shows the battery location. Gently pry the battery free from its socket, taking care to note the "+" and "-" orientation of the battery (Figure 27, 2).
6. Install the new battery in the socket.

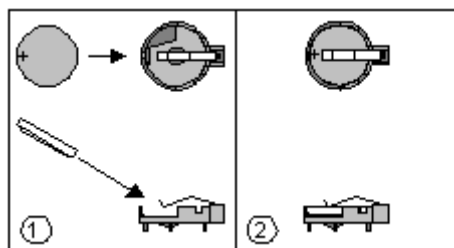

Figure 27: Removing the Battery

Chapter 3: Solving Problems

The first part of this chapter helps you identify and solve problems that might occur when the system is in use. The second part lists error code messages that might be displayed.

Please remember that if you cannot solve the problem by yourself then you should contact Viglen Technical Support for further assistance.

Viglen Technical Support can be reached in the following ways:

Telephone: 01727 201 850
Fax: 01727 201 858
Email: techsupport@viglen.co.uk

You can also look for support information on our web site:

<http://www.viglen.co.uk>

Device drivers and various useful utilities can be downloaded from our ftp site:

<http://download.viglen.co.uk/files/>

Resetting the System

Before checking your system for hardware problems, it is always a good idea to try resetting your computer and see if a re-boot can solve the problem. Most software related problems can be solved simply by re-booting your PC.

Table 4: Resetting the System

To do the following	Press
Soft boot: Clear the system memory and reload the operating system (also called warm reset).	<Ctrl + Alt + Del>
Cold boot: Clear the system memory, halt power to all peripherals, restart POST, and reload the operating system.	Power off/on or reset button (at front of the system)

Troubleshooting Procedures

This section provides a step-by-step troubleshooting procedure to identify a problem and locate its source.

CAUTION!

1. Turn off the system and any peripheral devices before you disconnect any peripheral cables from the system. Otherwise, you can permanently damage the system or the peripheral devices.
2. Make sure the system is plugged into a properly grounded power outlet.
3. Make sure your keyboard and video display are correctly connected to the system. Turn on the video display, and turn up its brightness and contrast controls to at least two-thirds of the maximum (refer to the documentation supplied with the video display).
4. If the operating system normally loads from the hard disk drive, make sure there is no diskette in the diskette drive. If the operating system normally loads from a diskette, insert the operating system diskette into the drive.
5. Turn on the system. If the power indicator does not light, but the system seems to be operating normally, the indicator is probably defective. Monitor the power-on self test (POST) execution. Each time you turn on the system, the POST checks the system board, memory, keyboard, and certain peripheral devices.

NOTE: If the POST does not detect any errors, the system beeps once and boots up.

Errors that do not prevent the boot process (non-fatal errors) display a message that looks similar to the following:

```
Error Message Line 1
Error Message Line 2
Press <DEL> for Set-up, <F1> to Boot
You can note the error and press <F1> to resume the boot-up process, or <DEL>
to enter Set-up.
```

Errors that prevent the boot process from continuing (fatal errors), are communicated by a series of audible beeps. If this type of error occurs, refer to the error codes and messages listed at the end of this chapter.

6. Confirm that the operating system has loaded.

Problems & Suggestions

Table 5: Problems and Suggestions

What happens	What to do
Application software problems	<p>Try resetting the system.</p> <p>Make sure all cables are installed correctly.</p> <p>Verify that the system board jumpers are set properly.</p> <p>Verify that your system hardware configuration is set correctly. In Setup, check the values against the system settings you recorded previously. If an error is evident (wrong type of drive specified, for example), make the change in Setup and reboot the system. Record your change.</p> <p>Make sure the software is properly configured for the system. Refer to the software documentation for information.</p> <p>Try a different copy of the software to see if the problem is with the copy you are using.</p> <p>If other software runs correctly on the system, contact the vendor of the software that fails.</p> <p>If you check all of the above with no success, try clearing CMOS RAM and reconfiguring the system. Make sure you have your list of system settings available to re-enter, because clearing CMOS RAM sets the options to their default values.</p>
Characters on-screen are distorted or incorrect	<p>Make sure the brightness and contrast controls are properly adjusted on the monitor.</p> <p>Make sure the video signal cable and power cables are properly installed.</p> <p>Make sure your monitor is compatible with the video mode you have selected.</p>
Characters do not appear on screen	<p>Make sure the video display is plugged in and turned on.</p> <p>Check that the brightness and contrast controls are properly adjusted.</p> <p>Check that the video signal cable is properly installed.</p> <p>Make sure a video board is installed, enabled, and the jumpers are positioned correctly.</p> <p>Reboot the system.</p>

Table 6: Problems and Suggestions (Continued)

What happens	What to do
CMOS RAM settings are wrong	If system settings stored in CMOS RAM change for no apparent reason (for example, the time of day develops an error), the backup battery may no longer have enough power to maintain the settings. Replace the battery (Chapter 2).
Diskette drive light does not go on when drive is in use or is tested by POST	Make sure the power and signal cables for the drive are properly installed. Check that the drive is properly configured and enabled in Setup.
Hard drive light does not go on when drive is in use or is tested by POST	Make sure the power and signal cables for the drive are properly installed. Make sure the front panel connector is securely attached to the system board headers. Check that the drive is properly configured and enabled in Setup. Check the drive manufacturer's manual for proper configuration for remote hard disk drive activity.
Power-on light does not go on	If the system is operating normally, check the connector between the system board and the front panel. If OK, the light may be defective.
Prompt doesn't appear after system boots	It's probably switched off. A serious fault may have occurred consult your dealer service department / Technical Support.
Setup, can't enter	If you can't enter Setup to make changes, check the switch that disables entry into Setup (Chapter 2). If the switch is set to allow entry into Setup, you might need to clear CMOS RAM to the default values and reconfigure the system in Setup.
System halts before completing POST	This indicates a fatal system error that requires immediate service attention. Note the screen display and write down any beep code emitted. Provide this information to your dealer service department / Technical Support.

Chapter 4: System BIOS

What is the BIOS?

The BIOS (Basic Input Output System) is an important piece of software which is stored in a ROM (Read Only Memory) chip inside the computer. It consists of the basic instructions for controlling the disk drives, hard disk, keyboard and serial/parallel ports. The BIOS also keeps a list of the specifications of the computer in battery-backed RAM (also known as the CMOS RAM) and provides a special Setup program to change this information.

The BIOS in your Viglen computer is guaranteed to be fully compatible with the IBM BIOS. It has been written by American Megatrends Inc, an industrial leader in the field of BIOS software.

The Power-On sequence

When the computer is first switched on, certain instructions in the BIOS are executed to test various parts of the machine. This is known as the POST (Power-On Self Test) routine. When you switch the computer on (or when you press the Reset button or press <Ctrl> + <Alt>+ <Delete> keys, which has the same effect), you can see on the monitor that it counts through the memory, testing it. The floppy disk drives are then accessed and tested, and the various interfaces are checked. If there are any errors, a message is displayed on the screen.

BIOS Upgrades

A new version of the BIOS can be upgraded from a bootable USB key using the AFUDE238.EXE utility. This utility does BIOS upgrades as follows:

- Updates the flash BIOS from a file on a disk or within the location of the utility.
- Updates the language section of the BIOS.
- Makes sure that the upgrade BIOS matches the target system to prevent accidentally installing a BIOS for a different type of system.

BIOS upgrades and the AFUDE238.EXE utility are available on the Viglen FTP site <http://download.viglen.co.uk/files/>

NOTE: Please review the instructions distributed with the upgrade utility before attempting a BIOS upgrade.

Using AFUDE238 to update the BIOS

The BIOS can be updated using the AFUDE238.EXE utility in DOS environment.

1. Save BIOS update zipped file to a temporary directory.
2. Extract the necessary files.
3. Copy the contents of the file to a bootable floppy disk, USB device or CD-ROM.
4. Boot the target PC with the device connected or inserted.
5. Select F11 during POST to display the Boot Menu and select your bootable device.
6. Type 'Flash.bat' to launch the BIOS update process.
7. The system will reboot once complete.

DO NOT shutdown or reset the system while updating the BIOS! Doing so may cause system boot failure!

When the BIOS update process is complete, the utility reboots the system.

BIOS Setup

This chapter provides basic information on the BIOS Setup program and allows you to configure the system for optimum use. You may need to run the Setup program when:

- An error message appears on the screen during the system booting up, and requests you to run BIOS SETUP.
- You want to change the default settings for customized features.

Note: The items under each BIOS category described in this chapter are under continuous update for better system performance. Therefore, the description may be slightly different from the latest BIOS and should be held for reference only.

➤ Entering BIOS Setup

Power on the computer and the system will start POST (Power On Self Test) process. When the message below appears on the screen, press key to enter Setup.

Press Delete key to enter BIOS setup Menu or Press F11 key to enter Boot Menu

If the message disappears before you respond and you still wish to enter Setup, restart the system by turning it OFF and On or pressing the RESET button. You may also restart the system by simultaneously pressing <Ctrl>, <Alt>, and <Delete> keys.

➤ Control Keys

<↑><↓>	Select Item
<←><→>	Select Screen
<Enter>	Select
<Esc>	Jumps to the Exit menu or returns to the main menu from a submenu
<+><->	Change Option
<F1>	General Help
<F6>	Load Optimized Defaults
<F10>	Save all the CMOS changes and exit

Figure 28: BIOS control keys

Getting Help

After entering the BIOS, the first screen you will see is the Main Menu.

Main Menu

The Main Menu lists the setup functions you can make changes to. You can use the arrow keys (↑↓) or mouse to select the item.

Sub-Menu

A sub-menu contains additional options for a field parameter. You can use arrow keys (↑↓) to highlight the field and press <Enter> to call up the sub-menu or use the mouse to click on the menu. Then you can use the control keys to enter values and the mouse or control keys move from field to field within a sub-menu. If you want to return to the main menu, just press the <Esc>.

General Help <F1>

The BIOS setup program provides a General Help screen. You can call up this screen from any menu by simply pressing <F1>. The Help screen lists the appropriate keys to use and the possible selections for the highlighted item. Press <Esc> to exit the Help screen.

The Menu Screen



Figure 29: Main Menu

BIOS Main Menu selection

The following options are available:

- **SETTINGS** - Use this menu to specify your settings for chipset features and boot devices.
- **OC** - This menu contains items of the frequency and voltage adjustments. Increasing the frequency can get better performance, however high frequency and heat can cause instability, we do not recommend general users to overclock.
- **M-FLASH** – This can be used to flash the BIOS.
- **OC PROFILE** – This can be used to manage overclocking profiles.
- **HARDWARE MONITOR** – Displays fan speeds and temperatures.
- **BOARD EXPLORER** – A layout of the board is displayed along with any connections it has such as drives connected to SATA ports.

- **Temperature monitor** - This block shows the temperature of the processor and the mainboard
- **System information** - This block shows the time, date, CPU name, CPU frequency, DRAM frequency, DRAM capacity and the BIOS version.
- **Menu display** - This area provides BIOS settings and information to be configured.
- **Language** - This allows you to select the language of the BIOS setting.
- **Boot device priority bar** - This bar shows the priority of the boot devices. The lighted icons indicate that the devices are available.

Settings Menu Screen

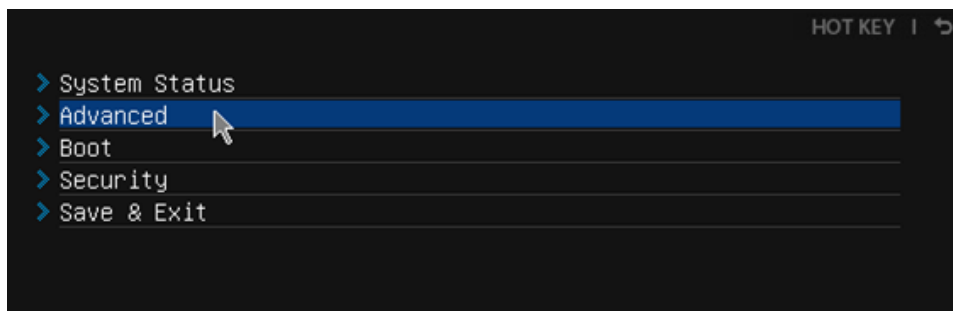

Figure 30: Settings Menu Screen

Advanced Sub Menu Screen

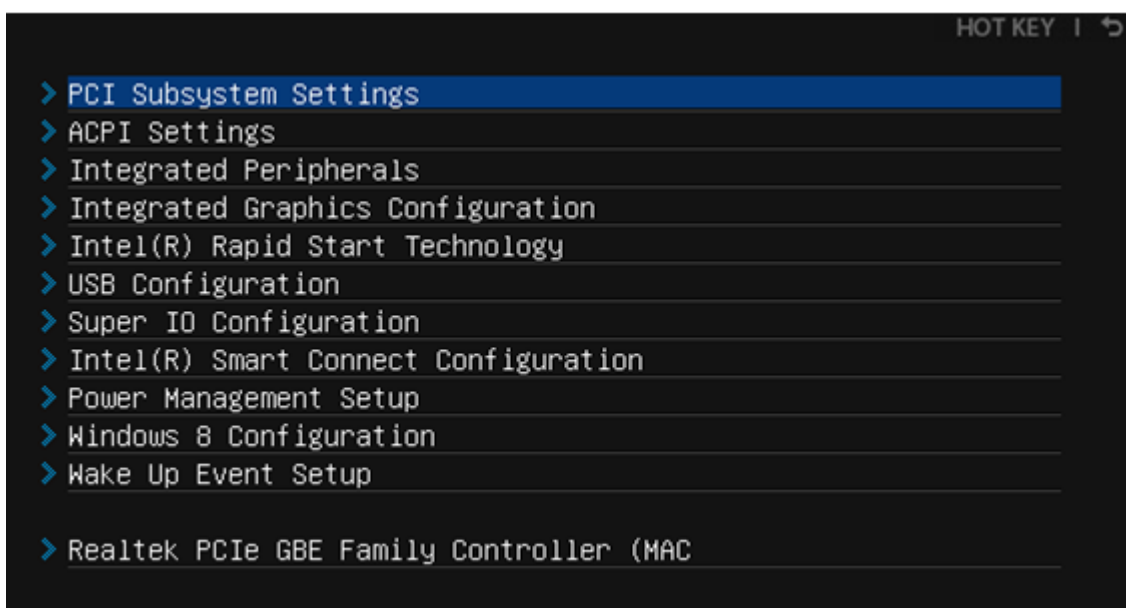

Figure 31: Advanced Sub Menu Screen

Configure system with Windows 8/8.1

- **Option for Win 8 Configuration** – In the **Advanced** sub menu navigate to **Windows 8/8.1 Configuration** and select it as seen below in the first screenshot. The second screenshot shows what will appear when you have selected Windows 8 Configuration. Select **Windows 8/8.1 Feature** and **Enable** it.

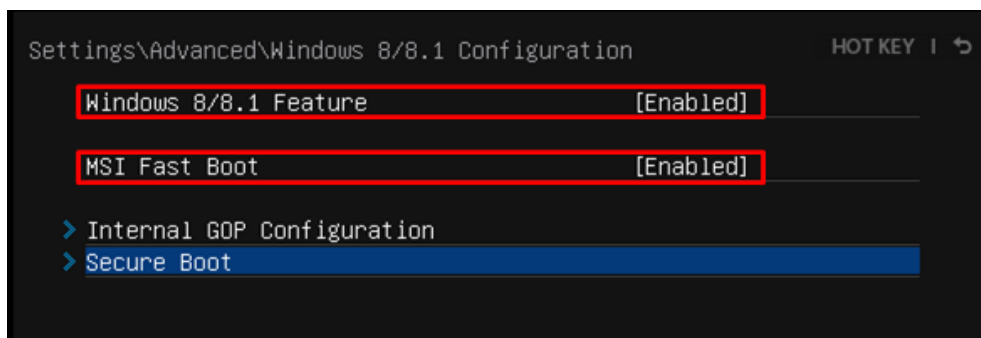
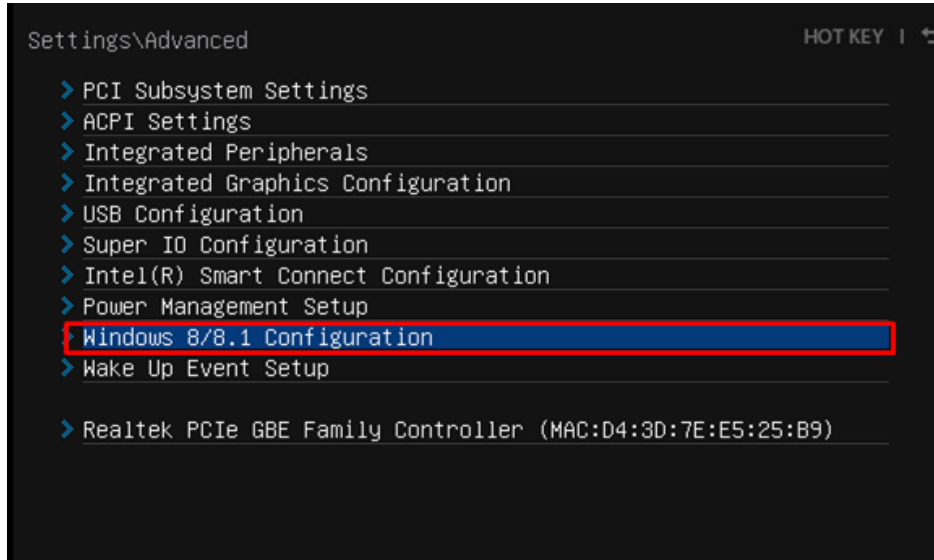

Figure 32: Windows 8 Required settings

Below is a list of all required settings which need to be **Enabled** for Windows 8/8.1

Windows 8/8.1 Feature	[Enabled]
MSI Fast Boot	[Enabled]
Secure Boot	[Enabled]

Note: After enabling Windows 8/8.1 Feature and MSI Fast Boot, save changes and restart system before enabling Secure Boot. To enable Secure Boot follow instructions on the next page.

- **Enabling Secure Boot** – After enabling Windows 8/8.1 Feature and MSI Fast Boot save changes, restart system and enter BIOS again as before to enable Secure Boot. Follow these instructions to enable **Secure Boot**.

1. Navigate to **Secure Boot** from within Windows 8/8.1 Feature and press Enter.
2. Change **Secure Boot Support** to **Enabled** and **Secure Boot Mode** to **Custom**.

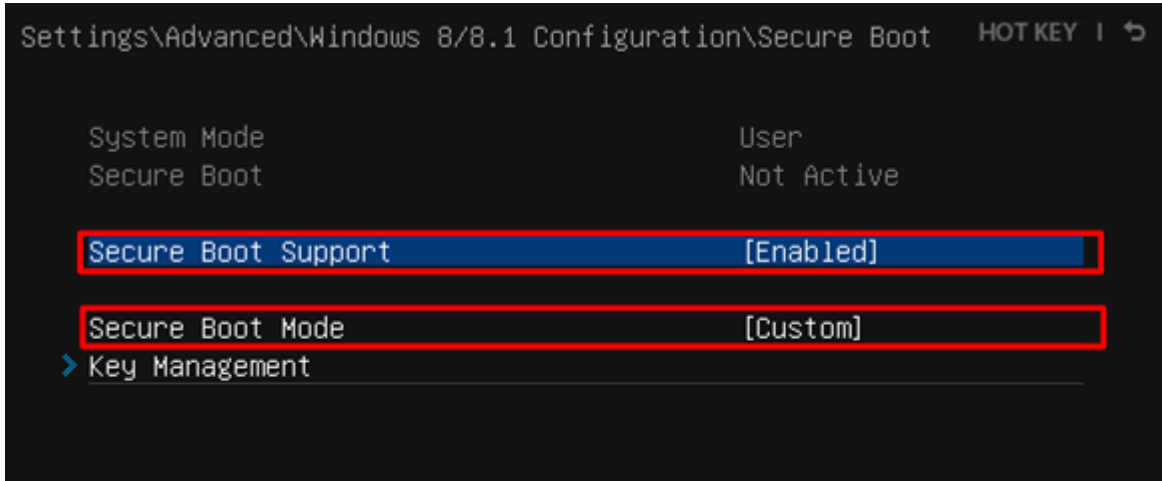

Figure 33: Secure Boot

3. Enter **Key Management**.
4. Change **Default Key Provision** to **Enabled** if not already Enabled. Press **Enter** on **Enroll All Factory Default Keys** and select **Yes** if prompted.

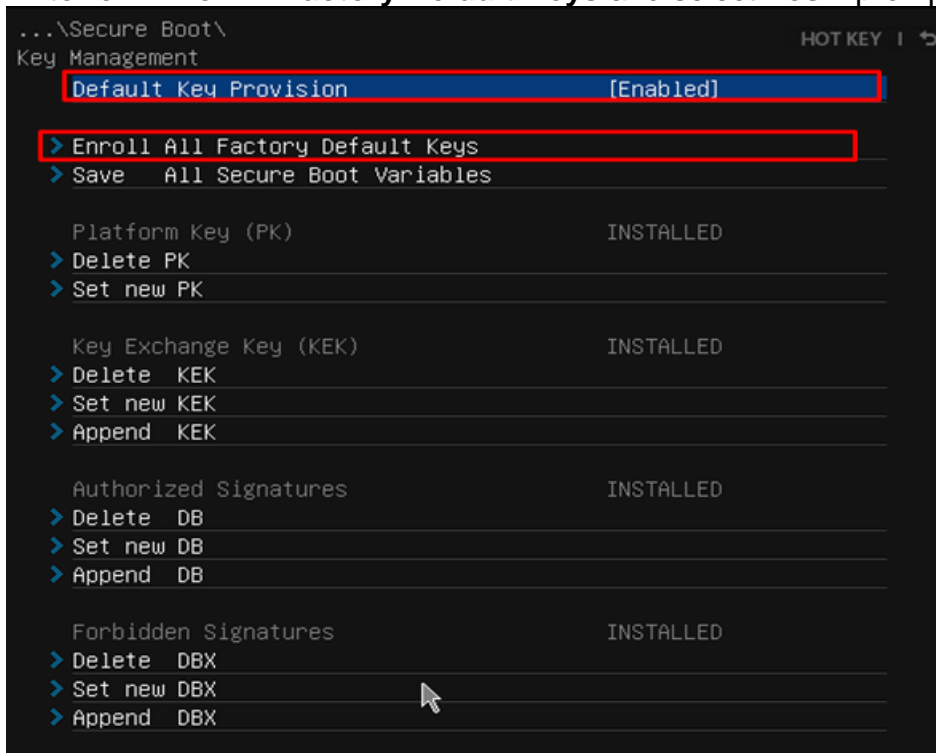

Figure 34: Key Management

5. Press **Esc** twice to exit Key Management and Secure Boot settings. Save changes and exit BIOS.

Note: Windows 8/8.1 Feature option should be set to **Disabled** if non Windows 8 operating system is to be configured.

Restoring Defaults and Saving Changes

Load Optimized Defaults: Use the arrow keys (←, →, ↑, ↓) or mouse to select the [Restore Defaults] in [Save & Exit] menu, and press <Enter> or double click. A pop-up message will appear, select [Yes] and press <Enter> to load the default settings for optimal system performance.

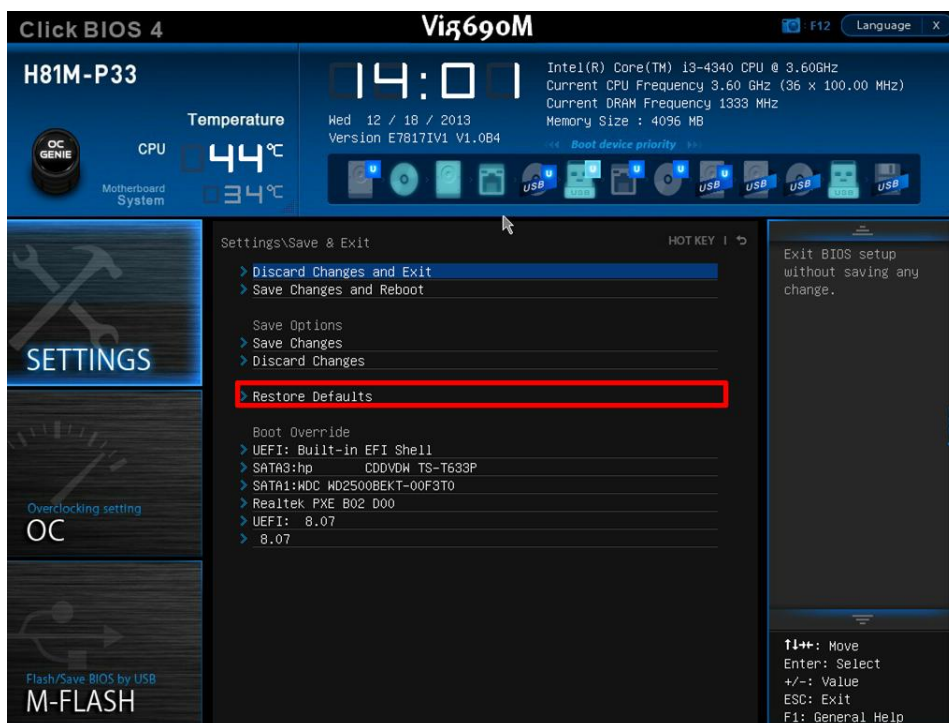

Figure 35: Restore Defaults

Setup Date/Time: Use the arrow keys (←, →, ↑, ↓) or mouse to navigate to [Settings] menu and then [System Settings], and press <Enter> or click. And then, you can set the Date, Time in their respective fields, by typing number you wish to be placed in field.

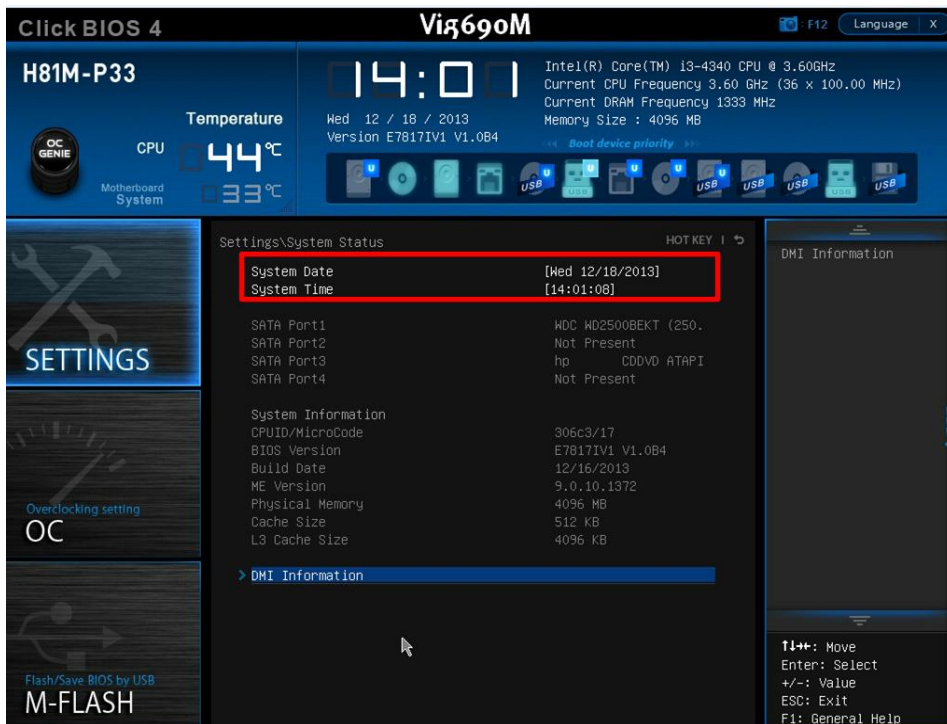

Figure 36: Setup Date/Time

Save & Exit Setup: Click on Settings and then Save & Exit. Then use arrow keys or mouse to select the [Save Changes & Reboot] and press <Enter> or double click. A pop-up message will appear, select [Yes] and press <Enter> to save the configurations and exit BIOS setup utility.

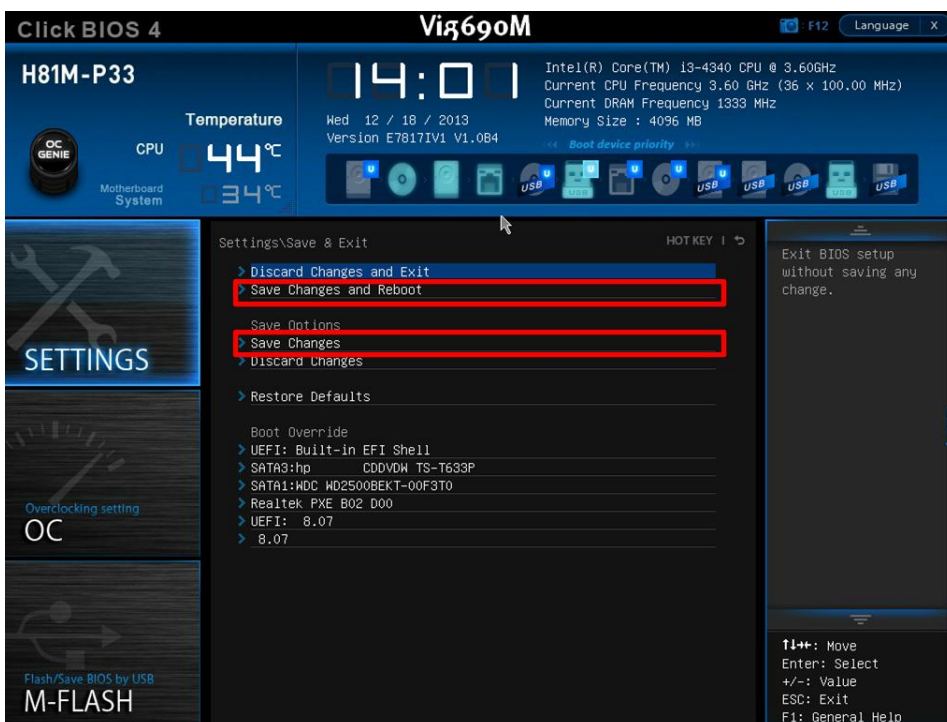

Figure 37: Save & Exit Setup

View DMI Information: the arrow keys (←, →, ↑, ↓) or mouse to select [System Status] in [Settings]. From here select [DMI Information].



Figure 38: DMI Information

Chapter 5: Suggestions

Viglen is interested in continuing to improve the quality and information provided in their manuals. Viglen has listed some questions that you may like to answer and return to Viglen. This will help Viglen help to keep and improve the standard of their manuals.

1. Is the information provided in this and other manuals clear enough?

2. What could be added to the manual to improve it?

3. Does the manual go into enough detail?

4. Would you like an on-line version of this manual?

5. How do you rate the Viglen Technical support and Service Departments?
