

Vi8711W Motherboard Manual

Vi8711W

**Great
Minds
Think**

viglen

Viglen, EMC and the 'CE' mark

CE Marking

European standards are being harmonised across borders. If products comply with the same standards in all European countries, product exporting and importing is made simple - paving our way to a common market. If you buy a product with a 'CE' mark on it (shown below), on the box, in the manual, or on the guarantee - it complies with the currently enforced directive(s).



Introduction to EMC

EMC (Electromagnetic Compatibility) is the term used to describe certain issues with RF (Radio Frequency) energy. Electrical items should be designed so they do not interfere with each other through RF emissions. E.g. If you turn on your microwave, your television shouldn't display interference if both items are CE marked to the EMC directive.

If emitted RF energy is not kept low, it can interfere with other electrical circuitry - E.g. Cars Automatic Braking Systems have been known to activate by themselves while in a strong RF field. As this has obvious repercussions ALL electrical products likely to cause RF related problems have to be 'CE' marked from 1st January 1996 onwards.

If a product conforms to the EMC directive, not only should its RF emissions be very low, but its immunity to RF energy (and other types) should be high. The apparatus has to resist many 'real world' phenomena such as static shocks and mains voltage transients.

Viglen's Environment laboratory

To gain a 'CE' mark, the Viglen computer range has had to undergo many difficult tests to ensure it is Electromagnetically Compatible. These are carried out in the in-house 'Environment lab' at Viglen Headquarters. We have made every effort to guarantee that each computer leaving our factory complies fully with the correct standards. To ensure the computer system maintains compliance throughout its functional life, it is essential you follow these guidelines.

- Install the system according to Viglen's instructions
- If you open up your Viglen:
 - Keep internal cabling in place as supplied.
 - Ensure the lid is tightly secured afterwards
 - Do not remove drive bay shields unless installing a 'CE' marked peripheral in its place
 - The clips or 'bumps' around the lips of the case increase conductivity - do not remove or damage.
 - Do not remove the ferrite ring from the L.E.D cables.
 - Only use your Viglen computer with 'CE' marked peripherals

This system has been tested in accordance with European standards for use in residential and light industrial areas - this specifies a 10 meter testing radius for emissions and immunity. If you do experience any adverse affects which you think might be related to your computer, try moving it at least 10 meters away from the affected item. If you still experience problems, contact Viglen's Technical Support department who will put you straight through to an EMC engineer - s/he will do everything possible to help. If modifications are made to your Viglen computer system, it might breach EMC regulations. Viglen take no responsibility (with regards to EMC characteristics) of equipment which has been tampered with or modified.



This symbol on the product or on its packaging indicates that the product shall not be treated as household waste. Instead it shall be handed over to the applicable collection point for recycling of electrical and electronic equipment. By ensuring this product is disposed of correctly, you will help prevent potential negative consequences for the environment and human health, which could otherwise be caused by inappropriate waste handling of this product. The recycling of materials will help to conserve natural resources. For more detailed information about recycling of this product, please contact your local city office, your household waste disposal service or XMA Ltd.

Copyrights and Trademarks

Please note

The material in this manual is subject to change without notice.

Trademarks

Microsoft, Windows XP Pro, Windows Vista, Windows 7, Windows 8/8.1, Windows 10 and MS-DOS are registered trademarks of Microsoft Corporation. IBM PC, XT, AT and PS/2 are trademarks of International Business Machines Corporation. Core i3/i5/i7™ and Pentium® are registered trademarks of Intel® Corporation. All other trademarks are acknowledged. Genie, Vig, Viglen, and Omnino are trademarks of Viglen Limited.

Copyright and Patents

This manual and all accompanying software and documentation are copyrighted and all rights reserved. This product, including software and documentation, may not, in whole or in part, be copied, photocopied, translated or reduced to any electronic or machine-readable form, without prior written consent except for copies retained by the purchaser for backup.

© Copyright 2015 Viglen Limited

All Rights Reserved

Vig711W Manual Version 1.0

Printed in the United Kingdom

Original power supply

Liability

No warranty or representation, either expressed or implied, is made with respect to this documentation, its quality, performance, merchantability or fitness for a particular purpose. As a result the documentation is licensed as is, and you, the licensee, are assuming the entire risk as to its quality and performance. The vendor reserves the right to revise this operation manual and all accompanying software and documentation and to make changes in the content without obligation to notify any person or organisation of the revision or change.

In no event will the vendor be liable for direct, indirect, special, incidental or consequential damages arising out of the use or inability to use this product or documentation, even if advised of the possibility of such damages. In particular, the vendor shall not have liability for any hardware, software or data stored or used with the product, including the costs of repairing, replacing or recovering such hardware, software or data.

Contents

Chapter 1: Motherboard Overview	4
Introduction	4
Feature Summary	5
System Board Components	13
Back Panel Connectors	14
Chapter 2: System Board Options	15
Before You Begin	16
System Board Jumper Settings	17
Motherboard Connectors	18
Upgrading the CPU	24
Installing & Removing Memory Modules	28
Replacing the Clock/CMOS RAM Battery	30
Chapter 3: Solving Problems	31
Resetting the System	31
Troubleshooting Procedures	32
Problems & Suggestions	33
Chapter 4: System BIOS	35
What is the BIOS?	35
The Power-On Sequence	35
BIOS Upgrades	36
BIOS Setup	37
Windows 8/8.1 BIOS Setting	40
Chapter 5: Suggestions	48

Chapter 1: Motherboard Overview

Introduction

This manual describes the Viglen Vig710W motherboard inside your computer. The motherboard is the most important part of your computer. It contains the CPU, memory and graphics circuitry that make the computer work in the correct manner.

The Vig710W motherboard with Mini-ITX form factor offers premium features. Integrated Graphics via HDMI, High Definition Audio via 2 flexible audio jacks and integrated 10/100/1000 network connection, as well as 2 USB 3.0 ports and 2 USB 2.0 ports to enrich your multimedia experience.

The Vig710W supports 4th generation Intel Core i3, i5, i7, Pentium and Celeron processors as well as being Microsoft Windows 7 Premium WHQL certified.

This manual contains technical information about the Viglen Vig710W motherboard and other hardware components inside your computer. If you are new to computers we recommend that you read the user guide first. If you are an experienced computer user this manual should provide all the information you will need to perform simple upgrades and maintenance.

We hope that this manual is both readable and informative. If you have any comments for suggestions about how we could improve the format then please fill out the form at the back of the manual and send it to us.

Above all we hope that you enjoy using your Viglen computer.

Feature Summary

Form factor:

- Thin Mini-ITX Form Factor: 170mm x 170mm

Processor:

- Intel® Core™ i7, Intel® Core™ i5, Intel® Core™ i3, Intel® Pentium®, Intel® Celeron® processors in an LGA1150 socket
- Integrated graphics processing (processors with Intel® Graphics Technology)
- External graphics interface controller
- Integrated memory controller

Chipset

- Intel® H81 Express Chipset

Memory

- Two SO-DIMM Slots
- Memory Module (SO-DIMM) sockets – only supports Voltage 1.5V
- Support for DDR3 1066/1333/1600 MHz SO-DIMMs
- Maximum 32GB Memory Size

Graphics

- Integrated graphics support for processors with Intel® graphics technology
- 1x HDMI® port supporting a maximum resolution of 1920x1200@60HZ

Audio

- Integrated HD audio codec by Realtek® ALC662
- Support JACK detection, multi-streaming and anti-pop functions
- With ALC105 amplifier to support speakers
- Front panel header

LAN

- Gigabit (10/100/1000 Mbits/s) LAN subsystem using the Realtek® RTL8111F Gigabit Ethernet Controller

Rear I/O Ports

- 1 x 19V Power Port
- 1x HDMI
- 1x Gigabit LAN (Realtek® RTL8111F)
- 1x Microphone
- 1x Headphone/Speaker
- 2x USB 3.0 Ports
- 2x USB 2.0 Ports

Internal Connectors

- 1 x Front Panel Connector (Reset, HD LED, Power LED, Power On/Off) (2 x 5 pin)
- 1 x 4-pin Chassis Speaker Connector
- 1 x Front Panel Audio Connector (2 x 5 pin)
- 2 x USB 2.0 Connector Support 4 x USB 2.0 Ports (2 x 5 pin)
- 1 x USB 2.0 Connector Supports 1 x USB 2.0 Port (1 x 5 pin)
- 2 x SATA 6Gb/s (SATAIII) Ports
- 1 x 5-pin DMIC
- 1 x 40-pin LVDS Connector
- 1 x 4-pin CPU Fan Connector
- 1 x 4-pin System Fan Connector
- 1 x 8-pin Display Brightness Connector
- 1 x 3-pin Backlight Inverter Voltage Selection Connector
- 1 x 3-pin SATA Power_ODD Connector
- 1 x 4-pin SATA Power_HDD Connector
- 1 x 3-pin Panel Voltage Selection Connector
- 1 x 3-pin Monitor Switch Connector
- 1 x Flat Panel Display Configuration Jumper (3 x 4 pin)
- 1 x 3-pin Monitor Switch Connector
- 1 x 3-pin Clear CMOS Header & Jumper
- 1 x TPM Connector (2 x 8 pin)

Expansion Capabilities

- 1 x Half Mini PCI Express slot supports PCIe signal
- 1 x Full Mini PCI Express slot supports PCIe signal (Default)

BIOS

- AMI EFI BIOS

Processor

The motherboard is designed to support the Intel Core i7/i5/i3, Pentium and Celeron processors in an LGA1150 socket.

Other processors may be supported in the future. This board is designed to support processors with a maximum TDP of 45 W.

Chipset

Intel H81 Express Chipset with Intel Flexible Display Interconnect (Intel FDI) and Direct Media Interface (DMI) interconnect provides interfaces to the processor, display, USB, SATA, LPC, LAN, and PCI Express interfaces. The Intel H81 Express Chipset is a centralized controller for the board's I/O paths.

Memory

The board has two SO-DIMM sockets and supports the following memory features:

- Two 204-pin DDR3 SDRAM Small Outline Dual Inline Memory Module (SODIMM) sockets
- Support for DDR3 1600 MHz, DDR3 1333 MHz, and DDR3 1066 MHz SODIMMs
- Support for 1GB, 2GB, 4GB & 8GB memory technology
- Support for up to 32 GB of system memory with two 16GB SO-DIMMs
- Support for non-ECC memory
- Support for 1.5 V (standard voltage) JEDEC memory
- Support for XMP memory

NOTE

To be fully compliant with all applicable DDR SDRAM memory specifications, the board should be populated with SO-DIMMs that support the Serial Presence Detect (SPD) data structure. This allows the BIOS to read the SPD data and program the chipset to accurately configure memory settings for optimum performance. If non-SPD memory is installed, the BIOS will attempt to correctly configure the memory settings, but performance and reliability may be impacted or the SO-DIMMs may not function under the determined frequency.

Memory Configurations

The 4th Intel Core generation Intel Core processor families support the following types of memory organization:

- Dual channel (Interleaved) mode. This mode offers the highest throughput for real world applications. Dual channel mode is enabled when the installed memory capacities of both SO-DIMM channels are equal. Technology and device width can vary from one channel to the other but the installed memory capacity for each channel must be equal. If different speeds SO-DIMMs are used between channels, the slowest memory timing will be used.
- Single channel (Asymmetric) mode. This mode is equivalent to single channel bandwidth operation for real world applications. This mode is used when only a single SO-DIMM is installed or the memory capacities are unequal. Technology and device width can vary from one channel to the other. If different speed SO-DIMMs is used between channels, the slowest memory timing will be used.
- Flex mode. This mode provides the most flexible performance characteristics. The bottommost DRAM memory (the memory that is lowest within the system memory map) is mapped to dual channel operation; the topmost DRAM memory (the memory that is nearest to the 8 GB address space limit), if any, is mapped to single channel operation. Flex mode results in multiple zones of dual and single channel operation across the whole of DRAM memory. To use flex mode, it is necessary to populate both channels.

Graphics Subsystem

The board supports system graphics through Intel Graphics Technology.

Integrated Graphics

The board supports integrated graphics through the Intel® Flexible Display Interface (Intel® FDI) for processors with Intel Graphics Technology.

NOTE: *If using a processor with integrated graphics, the board will support only two of the integrated graphics interfaces simultaneously: VGA, HDMI.*

High-Definition Multimedia Interface (HDMI)

The HDMI port supports standard, enhanced, or high-definition video, plus multichannel digital audio on a single cable. It is compatible with all ATSC and DVB HDTV standards and supports 8 full range channels at 24-bit/96kHz audio of lossless audio formats such as Dolby TrueHD or DTS HD Master Audio. The maximum supported resolution is 1920 x 1200 at 60 Hz refresh (WUXGA).

The HDMI port is compliant with the HDMI 1.3 specification.

Audio Subsystem

The motherboard supports Intel High Definition Audio through a Realtek ACL662 audio codec. The following software features are supported

- Compatible with Windows Vista Premium (complies with Microsoft WLP 3.08 specifications)
- WaveRT-based audio function driver and logo ready for Windows Vista
- Direct Sound 3D™ compatible
- A3D™ compatible
- I3DL2 compatible
- HRTF 3D Positional Audio
- Friendly user interface for 2-foot or 10-foot remote control applications
- Emulation of 26 sound environments to enhance gaming experience
- 10 Software Equalizer Bands
- Voice Cancellation and Key Shifting in Karaoke mode
- Windows Vista style configuration panel to improve user experience
- Microphone Acoustic Echo Cancellation (AEC), Noise Suppression (NS), and Beam Forming (BF) technology for voice application
- Features Dolby® Digital Live and DTS® CONNECT™ software (Optional)
- Features Dolby® Home Theater software (Optional)

These audio connectors are used for audio devices. It is easy to differentiate between audio effects according to the colour of audio jacks.



Figure 1: Audio Connectors

- Line-Out (Green) - Line Out, is a connector for speakers or headphones.
- Mic (Pink) - Mic, is a connector for microphones.

LAN Subsystem

The ethernet controllers support the following features:

- 10/100/1000 BASE-T IEEE 802.3 compliant

RJ-45 LAN Connector LEDs

The two LEDs are built into the RJ-45 LAN connector located on the back panel. These LEDs indicate the status of the LAN as shown in Table 1.

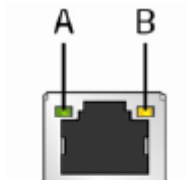

<i>Item</i>	<i>Description</i>
A	Link/Activity LED (Green)
B	Link Speed LED (Orange/Yellow)

Figure 2: LAN Connector LED Locations

Table 1: LAN LED Status

LED	LED Colour	LED State	Description
Link	Green	Off	LAN activity is occurring.
		On	LAN link is established.
		Blinking	LAN activity is occurring.
Data rate	Green/yellow		10 Mb/s data rate is selected.
			100 Mb/s data rate is selected.
			1000 Mb/s data rate is selected.

Universal Serial Bus (USB)

The motherboard supports up to Eight USB ports. The port arrangement is as follows:

- Two USB 3.0 ports are implemented with stacked back panel connectors
- Two USB 2.0 ports are implemented with stacked back panel connectors
- Five USB 2.0 front panel ports are implemented through three dual-port internal headers

NOTE: Computer systems that have an unshielded cable attached to a USB port may not meet FCC Class B requirements, even if no device or a low-speed (sub-channel) USB device is attached to the cable. Use shielded cable that meets the requirements for high-speed (fully rated) devices.

SATA Support

The board provides two 3GB/s SATA connectors, which support one device per connector.

NOTE: By default the SATA mode is set to AHCI in the BIOS to improve system performance. During Microsoft Windows XP installation, you must press F6 to install the AHCI drivers. Both Microsoft Windows Vista and Microsoft Windows 7 include the necessary RAID drivers for both AHCI and RAID without the need to install separate RAID drivers using the F6 switch in the operating system installation process. It is advised to install the latest AHCI drivers to improve system performance.

Expansion Slots

The motherboard provides the following expansion capability:

- One PCI Express Half-Mini Card slot
- One PCI Express Full-Mini Card slot

Real-Time Clock, CMOS SRAM, and Battery

A coin-cell battery (CR2032) powers the real-time clock and CMOS memory. When the computer is not plugged into a wall socket, the battery has an estimated life of three years. When the computer is plugged in, the standby current from the power supply extends the life of the battery.

The clock is accurate to ± 13 minutes/year at 25 °C with power applied through the power supply 5V STBY rail.

NOTE: If the battery and AC power fail, date and time values will be reset and the user will be notified during POST. When the voltage drops below a certain level, the BIOS Setup program settings stored in CMOS RAM (for example, the date and time) might not be accurate. Replace the battery with an equivalent one.

BIOS

The BIOS provides the Power-On Self-Test (POST), the BIOS Setup program, and the PCI/PCI Express and SATA auto-configuration utilities. The BIOS is stored in the Serial Peripheral Interface (SPI) Flash memory device.

SATA Auto Configuration

If you install a SATA device (such as a hard disk drive) in your computer, the auto-configuration utility in the BIOS automatically detects and configures the device for your computer. You do not need to run the BIOS Setup program after installing a SATA device. You can override the auto-configuration options by specifying manual configuration in the BIOS Setup program.

BIOS Security Passwords

The BIOS includes security features that restrict whether the BIOS Setup program can be accessed and who can boot the computer. A supervisor password and a user password can be set for the BIOS Setup and for booting the computer, with the following restrictions:

- The administrator password gives unrestricted access to view and change all Setup options. If only the administrator password is set, pressing <Enter> at the password prompt of Setup gives the user restricted access to Setup.
- If both the administrator and user passwords are set, you must enter either the supervisor password or the user password to access Setup. Setup options are then available for viewing and changing depending on whether the supervisor or user password was entered.
- Setting a user password restricts who can boot the computer. The password prompt is displayed before the computer is booted. If only the supervisor password is set, the computer boots without asking for a password. If both passwords are set, you can enter either password to boot the computer.

System Board Components

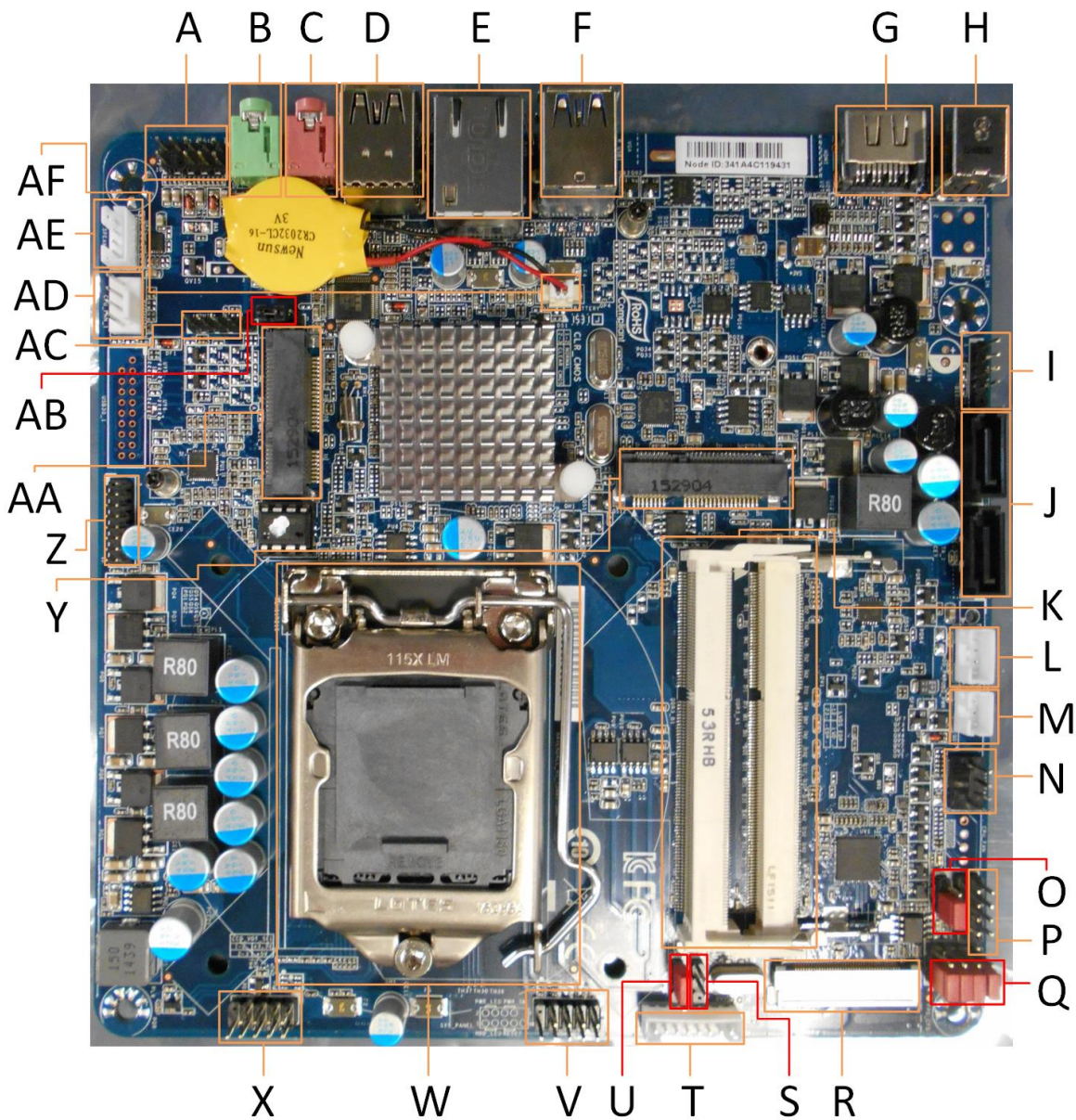

Figure 3: Motherboard Layout

Table 2: Motherboard Connectors

A	Front Panel Audio Header	Q	Front Panel Display Selector
B	Microphone	R	LVDS Connector
C	Speaker	S	Monitor Switch Selector
D	USB 2.0 Port	T	Display Brightness Header
E	LAN Port	U	Inverter Voltage Selector
F	USB 3.0 Port	V	USB2.0_12 Header
G	HDMI Port	W	CPU Socket
H	External Power Connector	X	USB2.0_34 Header
I	USB2.0 Single Header	Y	Mini PCI-E Full-card Slot
J	SATA Ports	Z	TPM Connector Header
K	SoDIMM Slots	AA	Mini PCI-E Half-card Slot
L	SATA Power_HDD	AB	Clear_CMOS
M	SATA Power_ODD	AC	DMIC Header
N	System Fan Header	AD	CPU Fan Header
O	LCD Voltage Selector	AE	Chassis Speaker Connector
P	Front Panel Header	AF	Battery Connector

Back Panel Connectors

The Motherboard external IO connectors are attached to a metallic I/O shield. This shield serves several purposes:

- It protects the sensitive Motherboard from any external EMC interference.
- It stops the computer from interfering with other electrical devices.
- It allows the Motherboard to be easily upgraded in the future without having to resort to buying a whole new case. Simply change the I/O shield to match the Motherboard.



Figure 4: Back Panel Connectors

- **Power Jack** – the board can be powered through a 19 V DC connector on the back panel. The back panel DC connector is compatible with a 7.4 mm/OD (outer diameter) and 5.1 mm/ID (inner diameter) plug, where the inner contact is +19 ($\pm 10\%$) V DC and the shell is GND. The maximum current rating is 12 A.
- **HDMI Port** - The High-Definition Multimedia Interface (HDMI) is an all-digital audio/video interface capable of transmitting uncompressed streams. HDMI supports all TV format, including standard, enhanced, or high-definition video, plus multi-channel digital audio on a single cable.
- **USB 3.0 Ports** - The USB 3.0 ports are for attaching USB devices such as keyboard, mouse, or other USB compatible devices.
- **LAN Port** - The standard RJ-45 LAN jack is for connection to the Local Area Network (LAN). You can connect a network cable to it.
- **USB 2.0 Ports** - The USB 2.0 ports are for attaching USB devices such as keyboard, mouse, or other USB compatible devices.
- **Audio Ports** - These audio connectors are used for audio devices (MIC-IN, LINE-OUT).

Note:

The back panel audio line out connectors is designed to power headphones or amplified speakers only. Poor audio quality occurs if passive (non-amplified) speakers are connected to this output.

Chapter 2: System Board Options

The Vig710W motherboard is capable of accepting Intel® Core i3, i5, i7 processors and Intel Pentium processors. RAM can be upgraded to a maximum of 16GB using DDR3 1066, 1333MHz or 1600MHz Non ECC Unbuffered memory.

WARNING!

Unplug the system before carrying out the procedures described in this chapter. Failure to disconnect power before you open the system can result in personal injury or equipment damage. Hazardous voltage, current, and energy levels are present in this product. Power switch terminals can have hazardous Voltages present even when the power switch is off.

The procedures assume familiarity with the general terminology associated with personal computers and with the safety practices and regulatory compliance required for using and modifying electronic equipment.

Do not operate the system with the cover removed. Always replace the cover before turning on the system.

As the colours of the wires in the mains lead of this computer may not correspond with the coloured markings identifying the terminals in your plug precede as follows:

The wire which is coloured **green-and-yellow** must be **connected** to the **terminal** in the plug which is marked by the letter **E** or by the safety Earth symbol **Q** or coloured green or **green-and-yellow**.

The wire which is coloured blue must be connected to the terminal which is marked with the letter **N** or coloured **black**.

The wire which is coloured brown must be connected to the terminal which is marked with the letter **L** or coloured **red**.

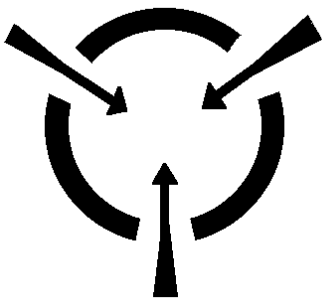

CAUTION!

The Viglen Vig710W motherboard and associated components are sensitive electronic devices. A small static shock from your body can cause expensive damage to your equipment.

BEFORE YOU BEGIN

Make sure you are earthed and free of static charge before you open the computer case. If you are unsure about upgrading your computer, return it to Viglen so a qualified engineer can perform the upgrade.

STEPS TO TAKE TO PREVENT STATIC DISCHARGE:

1. The best way to prevent static discharge is to buy an anti-static strap from your local electrical shop. While you are wearing the strap and it is earthed, static charge will be harmlessly bled to ground.
2. Do not remove the component from its anti-static protective packaging until you are about to install it.
3. Hold boards by the edges - try not to touch components / interface strips etc.

NOTE: *We recommend that you return your computer to the service department for upgrading. Any work carried out is fully guaranteed. Upgrades should only be carried out by persons who are familiar with handling IC's, as incorrect installation will invalidate the guarantee.*

System Board Jumper Settings

CAUTION

Do not move the jumper with the power on. Always turn off the power and unplug the power cord from the computer before changing a jumper setting. Otherwise, the board could be damaged.

- **Clear CMOS Jumper: CLR_CMOS**

The configuration Jumper (CLR_CMOS) allows the user to clear the CMOS. The CMOS RAM onboard has a power supply from an external battery to keep the data of the system configuration. The CMOS RAM allows the system to automatically boot OS every time it is turned on.



(Use a metal object to temporarily short these two pins.)

Pin	Status
1-2	Normal
2-3	Clear CMOS

Figure 5: Clear CMOS jumper

Motherboard Connectors

There are connectors on the motherboard for the Power supply, HD audio, fans, front panel audio, front panel USB and front panel connectors. The location and/or details of these connections are shown below.

Front Panel Connectors: SYS_PANEL

These connectors are for electrical connection to the front panel switches and LEDs. The SYS_PANEL is compliant with Intel® Front Panel I/O Connectivity Design Guide.

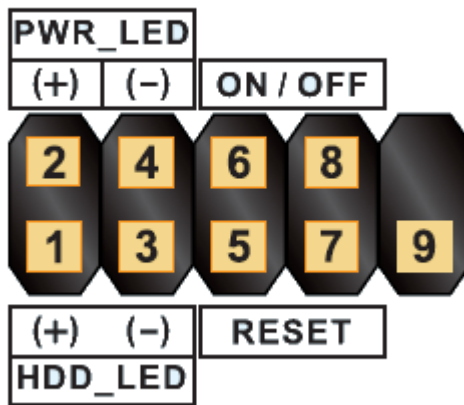

Figure 6: Front Panel Connectors

Table 3: Front Panel Connectors (Sys_Panel)

Pin	Connector	Comments
1-3	Hard Drive Activity LED Header	Pins 1 and 3 can be connected to an LED to provide a visual indicator that data is being read from or written to a hard drive. Proper LED function requires a Serial ATA hard drive connected to an onboard Serial ATA connector.
5-7	Reset Switch Header	Pins 5 and 7 can be connected to a momentary single pole, single throw (SPST) type switch that is normally open. When the switch is closed, the board resets and runs the POST.
2-4	Power/Sleep LED Header	Pins 2 and 4 can be connected to a one- or two-colour LED. This display if the computer is active or not.
6-8	Power Switch Header	Pins 6 and 8 can be connected to a front panel momentary-contact power switch. The switch must pull the SW_ON# pin to ground for at least 50 ms to signal the power supply to switch on or off. (The time requirement is due to internal debounce circuitry on the board.) At least two seconds must pass before the power supply will recognize another on/off signal.

Power Connectors

External 12V Power Connector

The board can be powered with a 19V DC external power supply through the 19V DC connector on the back panel. The back panel connector accepts plugs with an inner diameter of 5.5mm and an outer diameter of 7.5mm.

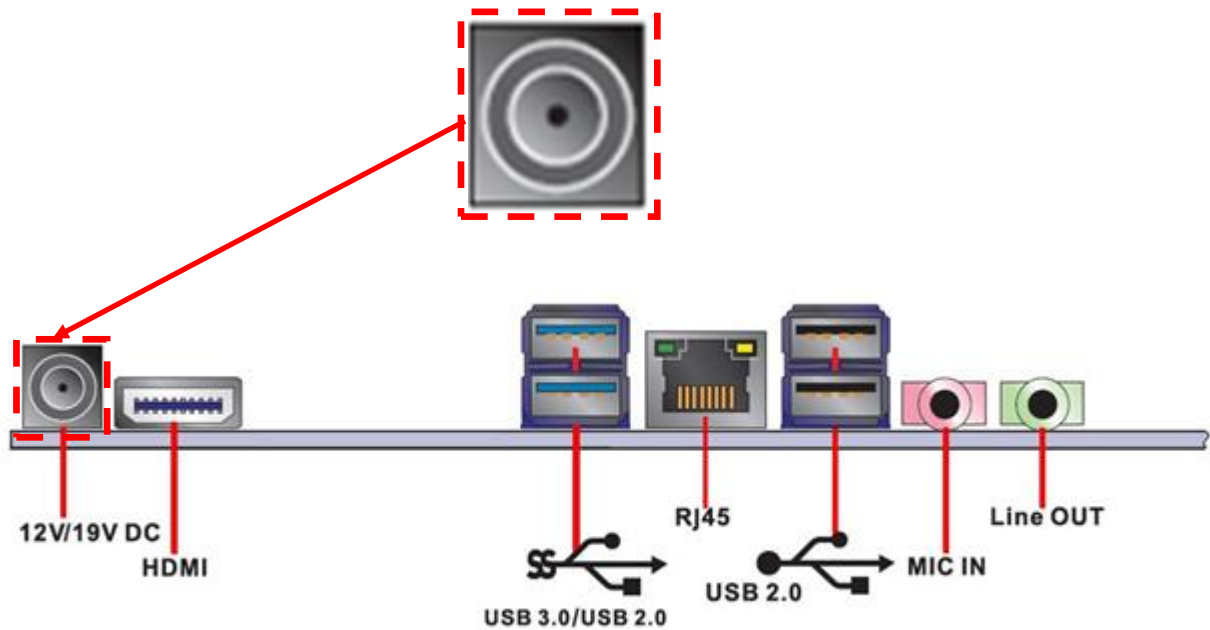

Figure 7: Back Panel

NOTE:

Note: DC Power connector supports 19V power Adapter. The back panel DC connector is compatible with a 7.4 mm/OD (outer diameter) and 5.1 mm/ID (inner diameter) plug, where the inner contact is +19 ($\pm 10\%$) V DC and the shell is GND. The maximum current rating is 12 A.

Front Panel Audio Connector: FP_AUDIO

This connector allows you to connect the front panel audio and is compliant with Intel® Front Panel I/O Connectivity Design Guide.

HD Audio Front Audio Header



Figure 8: Front panel audio connector

Table 4: Front panel audio header for HD audio

Pin	Signal Name	Pin	Signal Name
1	[Port 1] Left channel	2	Ground
3	[Port 1] Right channel	4	PRESENCE# (Dongle present)
5	[Port 2] Right channel	6	[Port 1] SENSE_RETURN
7	SENSE_SEND (Jack detection)	8	Key (no pin)
9	[Port 2] Left channel	10	[Port 2] SENSE_RETURN

Front USB Connector: USB20_34, USB20_12

This connector, compliant with Intel® I/O Connectivity Design Guide, is ideal for connecting high-speed USB interface peripherals such as USB HDD, digital cameras, MP3 players, printers, modems and the like.

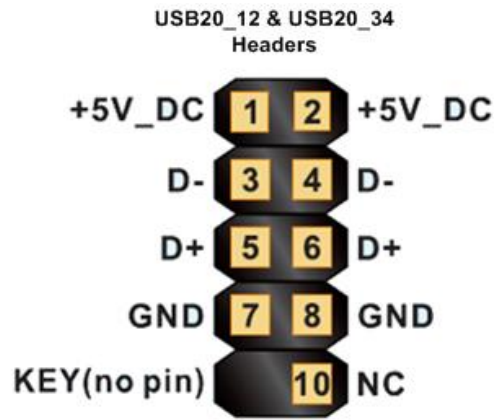

Figure 9: Front USB connectors

Front USB Connector: USB20_5



Figure 10: Front USB connector - single

Fan Power Connectors: CPU_FAN, SYS_FAN

The fan power connectors support system cooling fan with +12V. When connecting the wire to the connectors, always note that the red wire is the positive and should be connected to the +12V; the black wire is Ground and should be connected to GND. The motherboard has a System Hardware Monitor chipset on-board, which must be used with fans specially designed with speed sensors to take advantage of the CPU fan control.

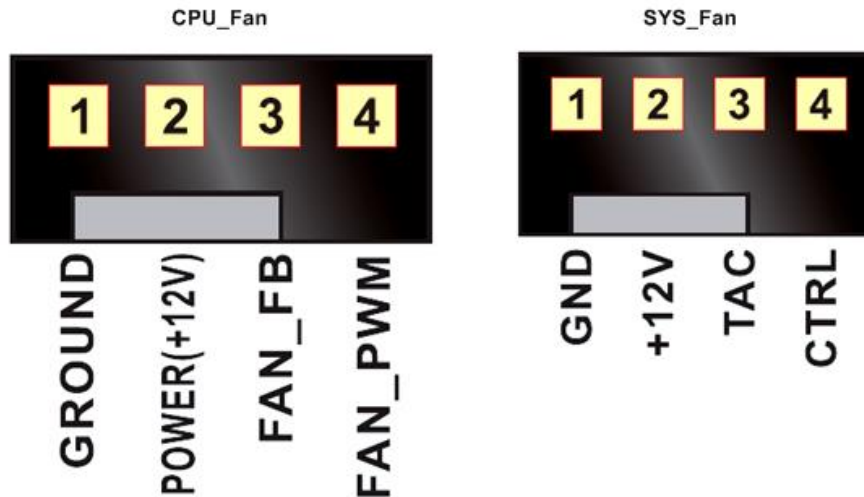

Figure 11: Fan Power connectors

Table 5: System FAN header, CPU FAN header

PIN	4-Wire support	PIN	3-Wire support
1	GND	1	GND
2	+12V power	2	+12V power
3	FAN_FB	3	TAC
4	FAN_PWM	4	Control

Serial ATA Connector: SATA0, SATA1

This connector is a high-speed Serial ATA interface port. Each connector can connect to one Serial ATA device.

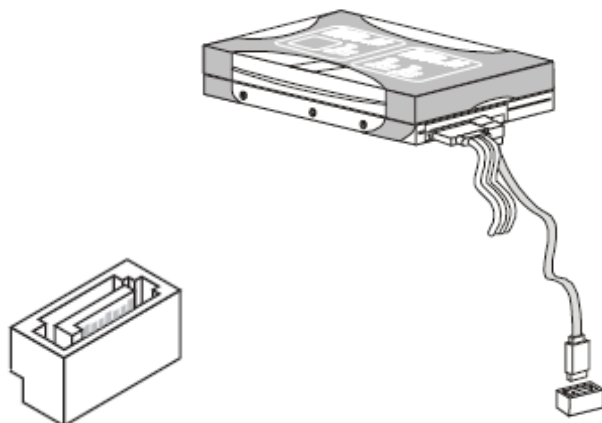

Figure 12: Serial ATA Connector

NOTE:

Please do not fold the serial ATA cable into 90-degree angle. Otherwise, data loss may occur during transmission.

Upgrading the CPU

CAUTION!

Before installing or removing a processor, make sure the AC power has been removed by unplugging the power cord from the computer; the standby power LED should not be lit. Failure to do so could damage the processor and the board.

To install a processor, follow these instructions:

1. Unlatch the processor socket lever by pushing it down and away from the socket. (Figure 13, A, B)

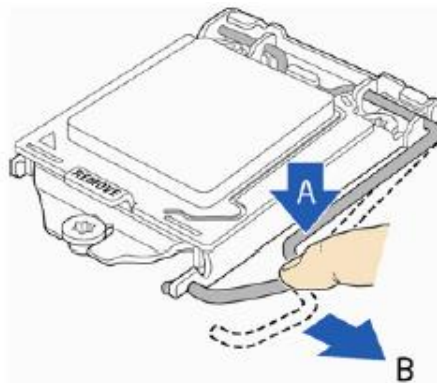

Figure 13: Unlatch the socket lever

2. Rotate the socket lever to lift the load plate away from the socket (Figure 14, A). Make sure that the load plate is in the fully open position (Figure 13, B) while being careful not to damage adjacent components. Do not touch the socket contacts.

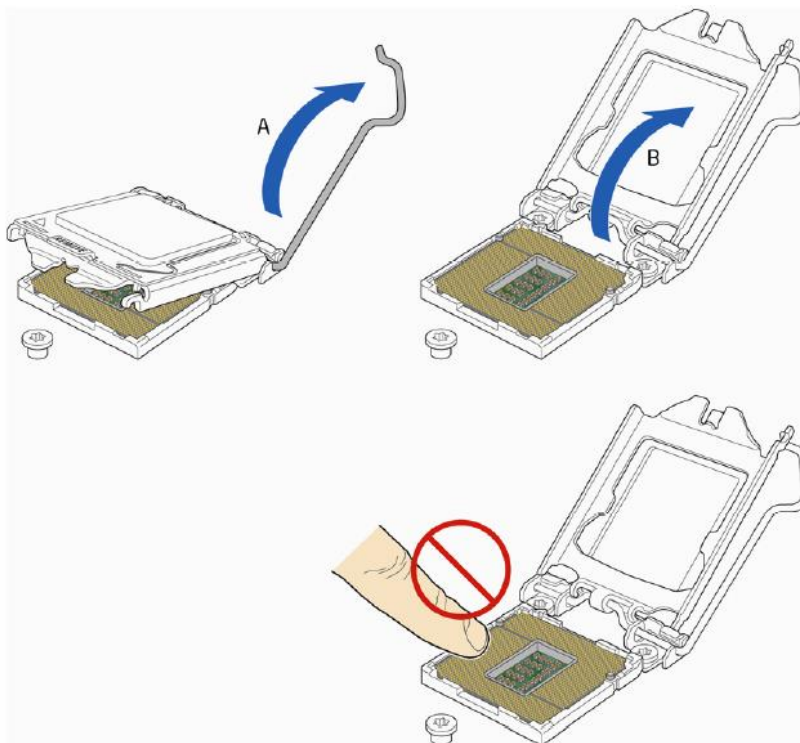

Figure 14: Lift the load plate

3. Remove the processor from its protective cover. Hold the processor only at the edges, being careful not to touch the bottom of the processor (see Figure 15).

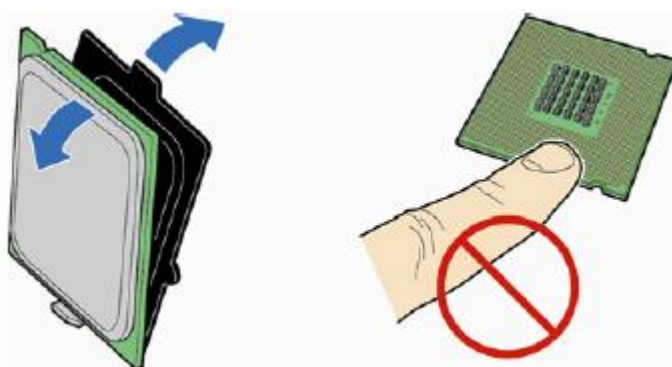

Figure 15: Remove the processor from the protective cover

Note: Do not discard the processor cover. Always replace the processor cover if you remove the processor from the socket.

4. Hold the processor with your thumb and index finger oriented as shown in Figure 16 to align your fingers with the socket finger cut-outs. Make sure that the processor Pin 1 indicator (gold triangle) is aligned with the Pin 1 chamfer on the socket (Figure 16, B) and that the notches on the processor align with the posts on the socket (Figure 16, C). Lower the processor straight down without tilting or sliding it in the socket (Figure 16, A).

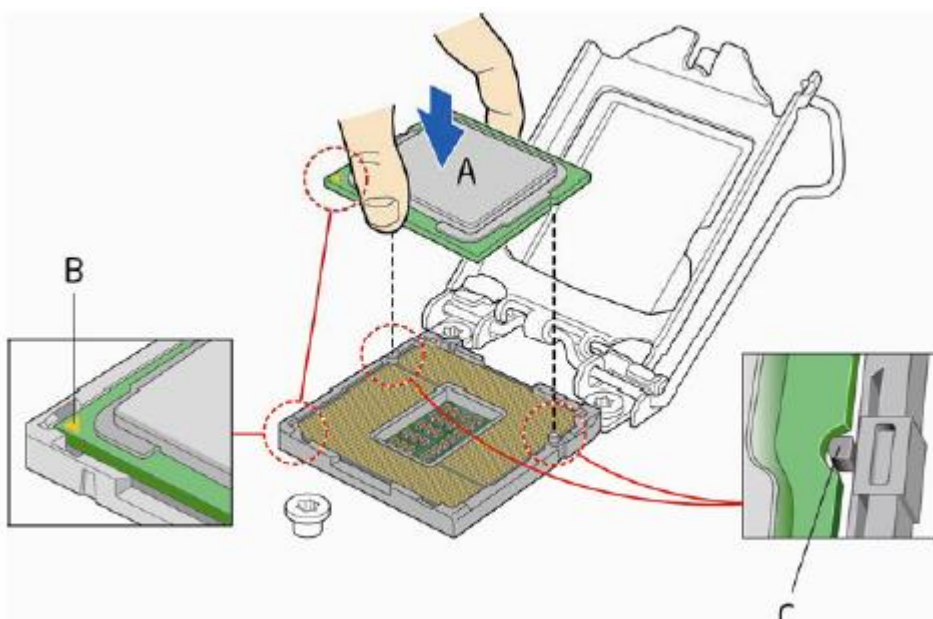

Figure 16: Install the processor

- Carefully lower the socket lever (Figure 17, A) while making sure that the front edge of the load plate slides under the shoulder screw cap as the lever is lowered. Latch the socket lever under the load plate tab (Figure 17, C, and D). The socket cover (Figure 17, B) will pop off as shown.

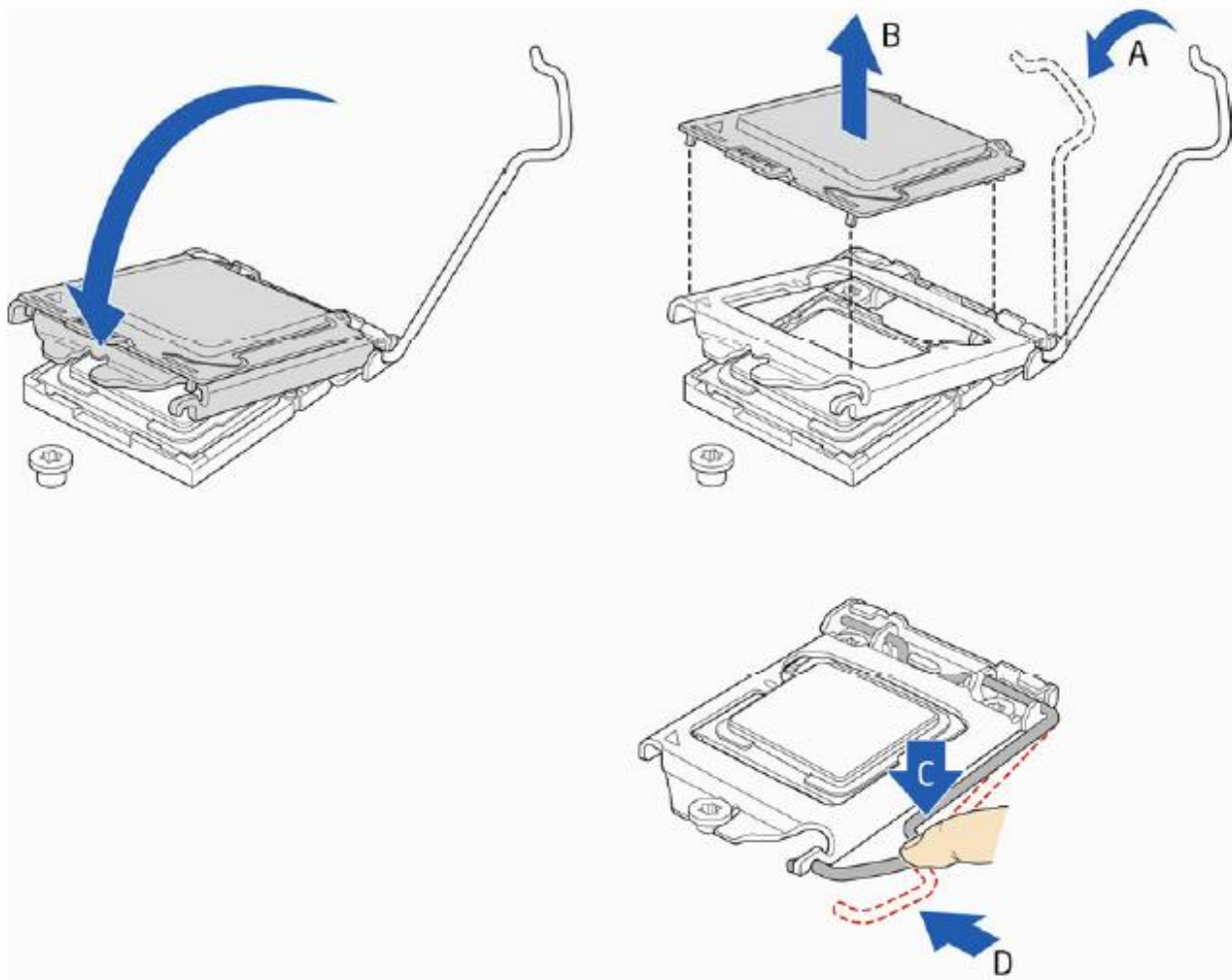

Figure 17: Secure the load plate in place

- Pick up the socket cover and remove it from the desktop board.

- **Connecting the Processor Fan Heat Sink Cable**

Connect the processor fan heat sink power cable to the 4-pin processor fan header (see Figure 18).

Make sure the four hooks are in the proper position before you install the cooler.

If the heatsink is held in by screws, position heatsink correctly and screw into place.

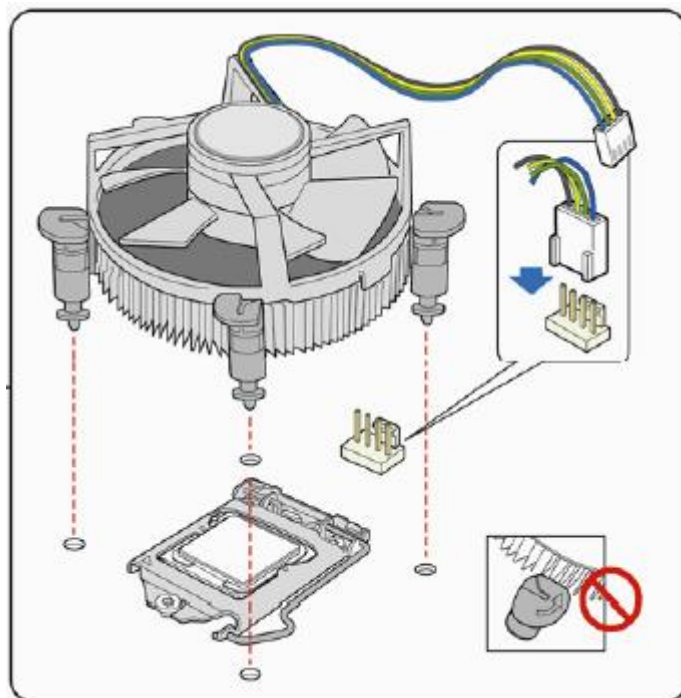

Figure 18: Connecting the processor fan heat sink power cable to the processor fan header

Installing & Removing Memory Modules

• Installing Memory

You can install up to 16GB of memory in each of the motherboard SO-DIMM sockets. The motherboard has two SO-DIMM sockets. The motherboard supports the following memory features:

- Two DDR3 SO-DIMMs with gold-plated contacts.
- Non-ECC (64-bit) memory.
- 1GB, 2GB, 4GB, 8GB and 16GB modules.
- only support Voltage 1.5V
- Memory Speeds 1066MHz, 1333MHz & 1600MHz

To install SO-DIMMs, follow these steps:

1. Observe the precautions in “Before You Begin”. Turn off the computer and all Peripheral devices.
2. Remove the computer cover and locate the DIMM sockets.
3. Holding the SO-DIMM by the edges, remove it from its antistatic package.
4. Position the SO-DIMM above the socket. Align the two small notches in the bottom edge of the SO-DIMM with the socket tabs. Insert the bottom edge of the SO-DIMM into the socket.
5. When the SO-DIMM is seated, push down until the retaining arms at either ends of the socket snap into place. Make sure the clips are firmly in place.
6. Replace the computer cover.

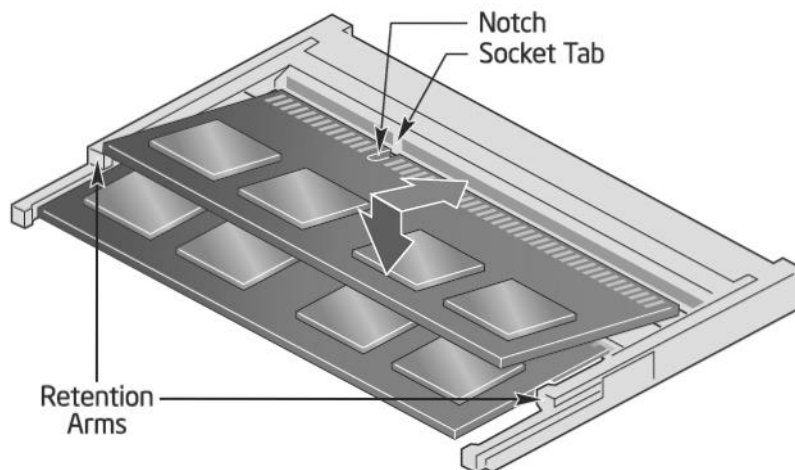

Figure 19: Memory Installation

Removing Memory

To remove a SO-DIMM, follow these steps:

1. Observe the precautions in "Before You Begin".
2. Turn off all peripheral devices connected to the computer. Turn off the computer.
3. Remove the computer cover.
4. Gently spread the retaining arms at each end of the socket. The SO-DIMM pops out of the socket. Hold the SO-DIMM by the edges, lift it away from the socket, and store it in an antistatic package.
5. Reinstall and reconnect any parts you removed or disconnected to reach the SO-DIMM sockets.

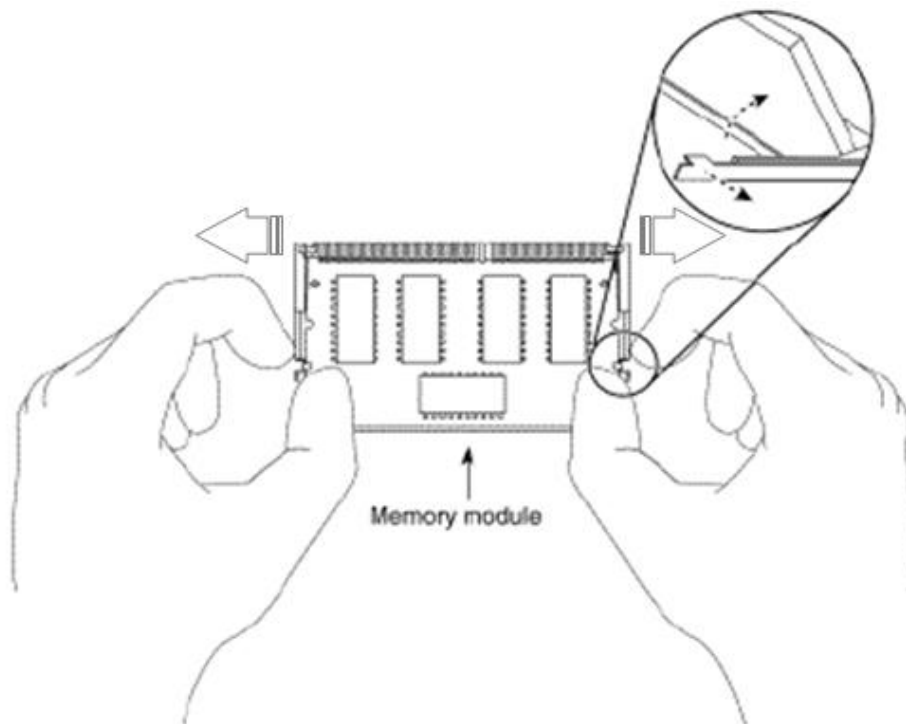

Figure 20: Removing Memory Modules

Replacing the Clock/CMOS RAM Battery

A lithium battery is installed in a socket on the system board.

The battery has an estimated life expectancy of seven years. When the battery starts to weaken, it loses voltage; when the voltage drops below a certain level, the system settings stored in CMOS RAM (for example, the date and time) may be wrong.

If the battery fails, you will need to replace it with a **CR2032** battery or an equivalent. As long as local ordinance permits, you may dispose of individual batteries as normal rubbish. Do not expose batteries to excessive heat or any naked flame. Keep all batteries away from children.

CAUTION!

Danger of explosion if the battery is incorrectly replaced. Replace only with the same or equivalent type recommended by Viglen. Discard used batteries according to manufacturer's instructions.

To replace the battery, carry out the following:

1. Observe the precautions in "Before You Begin."
2. Turn off all peripheral devices connected to the system.
3. Turn off the system.
4. Remove any components that are blocking access to the battery.
5. Figure 21 shows the battery location. Gently pry the battery free from its socket.
6. Install the new battery in the socket.

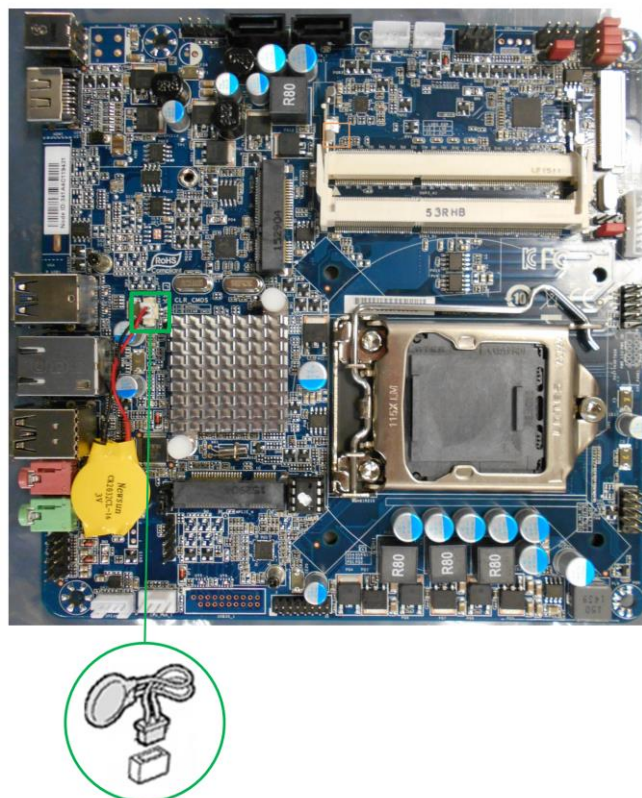

Figure 21: Removing the Battery

Chapter 3: Solving Problems

The first part of this chapter helps you identify and solve problems that might occur when the system is in use. The second part lists error code messages that might be displayed.

Please remember that if you cannot solve the problem by yourself then you should contact Viglen Technical Support for further assistance.

Viglen Technical Support can be reached in the following ways:

Telephone: 01727 201 850
Fax: 01727 201 858
Email: techsupport@viglen.co.uk

You can also look for support information on our web site:

<http://www.viglen.co.uk>

Device drivers and various useful utilities can be downloaded from our ftp site:

<http://download.viglen.co.uk/files/>

Resetting the System

Before checking your system for hardware problems, it is always a good idea to try resetting your computer and see if a re-boot can solve the problem. Most software related problems can be solved simply by re-booting your PC.

Table 6: Resetting the System

To do the following	Press
Soft boot: Clear the system memory and reload the operating system (also called warm reset).	<Ctrl + Alt + Del>
Cold boot: Clear the system memory, halt power to all peripherals, restart POST, and reload the operating system.	Power off/on or reset button (at front of the system)

Troubleshooting Procedures

This section provides a step-by-step troubleshooting procedure to identify a problem and locate its source.

CAUTION!

1. Turn off the system and any peripheral devices before you disconnect any peripheral cables from the system. Otherwise, you can permanently damage the system or the peripheral devices.
2. Make sure the system is plugged into a properly grounded power outlet.
3. Make sure your keyboard and video display are correctly connected to the system. Turn on the video display, and turn up its brightness and contrast controls to at least two-thirds of the maximum (refer to the documentation supplied with the video display).
4. If the operating system normally loads from the hard disk drive, make sure there is no diskette in the diskette drive. If the operating system normally loads from a diskette, insert the operating system diskette into the drive.
5. Turn on the system. If the power indicator does not light, but the system seems to be operating normally, the indicator is probably defective. Monitor the power-on self test (POST) execution. Each time you turn on the system, the POST checks the system board, memory, keyboard, and certain peripheral devices.

NOTE: If the POST does not detect any errors, the system beeps once and boots up.

Errors that do not prevent the boot process (non-fatal errors) display a message that looks similar to the following:

```
Error Message Line 1
Error Message Line 2
Press <DEL> for Set-up, <F1> to Boot
You can note the error and press <F1> to resume the boot-up process, or <DEL>
to enter Set-up.
```

Errors that prevent the boot process from continuing (fatal errors), are communicated by a series of audible beeps. If this type of error occurs, refer to the error codes and messages listed at the end of this chapter.

6. Confirm that the operating system has loaded.

Problems & Suggestions

Table 7: Problems and Suggestions

What happens	What to do
Application software problems	<p>Try resetting the system.</p> <p>Make sure all cables are installed correctly.</p> <p>Verify that the system board jumpers are set properly.</p> <p>Verify that your system hardware configuration is set correctly. In Setup, check the values against the system settings you recorded previously. If an error is evident (wrong type of drive specified, for example), make the change in Setup and reboot the system. Record your change.</p> <p>Make sure the software is properly configured for the system. Refer to the software documentation for information.</p> <p>Try a different copy of the software to see if the problem is with the copy you are using.</p> <p>If other software runs correctly on the system, contact the vendor of the software that fails.</p> <p>If you check all of the above with no success, try clearing CMOS RAM and reconfiguring the system. Make sure you have your list of system settings available to re-enter, because clearing CMOS RAM sets the options to their default values.</p>
Characters on-screen are distorted or incorrect	<p>Make sure the brightness and contrast controls are properly adjusted on the monitor.</p> <p>Make sure the video signal cable and power cables are properly installed.</p> <p>Make sure your monitor is compatible with the video mode you have selected.</p>
Characters do not appear on screen	<p>Make sure the video display is plugged in and turned on.</p> <p>Check that the brightness and contrast controls are properly adjusted.</p> <p>Check that the video signal cable is properly installed.</p> <p>Make sure a video board is installed, enabled, and the jumpers are positioned correctly.</p> <p>Reboot the system.</p>

Table 8: Problems and Suggestions (Continued)

What happens	What to do
CMOS RAM settings are wrong	If system settings stored in CMOS RAM change for no apparent reason (for example, the time of day develops an error), the backup battery may no longer have enough power to maintain the settings. Replace the battery (Chapter 2).
Diskette drive light does not go on when drive is in use or is tested by POST	Make sure the power and signal cables for the drive are properly installed. Check that the drive is properly configured and enabled in Setup.
Hard drive light does not go on when drive is in use or is tested by POST	Make sure the power and signal cables for the drive are properly installed. Make sure the front panel connector is securely attached to the system board headers. Check that the drive is properly configured and enabled in Setup. Check the drive manufacturer's manual for proper configuration for remote hard disk drive activity.
Power-on light does not go on	If the system is operating normally, check the connector between the system board and the front panel. If OK, the light may be defective.
Prompt doesn't appear after system boots	It's probably switched off. A serious fault may have occurred consult your dealer service department / Technical Support.
Setup, can't enter	If you can't enter Setup to make changes, check the switch that disables entry into Setup (Chapter 2). If the switch is set to allow entry into Setup, you might need to clear CMOS RAM to the default values and reconfigure the system in Setup.
System halts before completing POST	This indicates a fatal system error that requires immediate service attention. Note the screen display and write down any beep code emitted. Provide this information to your dealer service department / Technical Support.

Chapter 4: System BIOS

What is the BIOS?

The BIOS (Basic Input Output System) is an important piece of software which is stored in a ROM (Read Only Memory) chip inside the computer. It consists of the basic instructions for controlling the disk drives, hard disk, keyboard and serial/parallel ports. The BIOS also keeps a list of the specifications of the computer in battery-backed RAM (also known as the CMOS RAM) and provides a special Setup program to change this information.

The BIOS in your Viglen computer is guaranteed to be fully compatible with the IBM BIOS. It has been written by American Megatrends Inc, an industrial leader in the field of BIOS software.

The Power-On sequence

When the computer is first switched on, certain instructions in the BIOS are executed to test various parts of the machine. This is known as the POST (Power-On Self Test) routine. When you switch the computer on (or when you press the Reset button or press <Ctrl> + <Alt>+ <Delete> keys, which has the same effect), you can see on the monitor that it counts through the memory, testing it. The floppy disk drives are then accessed and tested, and the various interfaces are checked. If there are any errors, a message is displayed on the screen.

BIOS Upgrades

A new version of the BIOS can be upgraded from a bootable USB key using the AMIDEDOS.EXE utility or in Windows using the AEFUWIN utility that is available from the Viglen FTP site. This utility does BIOS upgrades as follows:

- Updates the flash BIOS from a file on a disk or within the location of the utility.
- Updates the language section of the BIOS.
- Makes sure that the upgrade BIOS match the target system to prevent accidentally installing BIOS for a different type of system.

BIOS upgrades and the AMIDEDOS.EXE utility is available on the Viglen FTP site <http://download.viglen.co.uk/files/>

NOTE: Please review the instructions distributed with the upgrade utility before attempting a BIOS upgrade.

Using AMIDEDOS.EXE to update the BIOS

The BIOS can be updated using the AMIDEDOS.EXE utility in DOS environment.

1. Save BIOS update zipped file to a temporary directory.
2. Extract the necessary files.
3. Copy the contents of the file to a bootable floppy disk, USB device or CD-ROM.
4. Boot the target PC with the device connected or inserted.
5. Select F7 during POST to display the Boot Menu and select your bootable device.
6. Type 'Flash.bat' to launch the BIOS update process.
7. The system will reboot once complete.

DO NOT shutdown or reset the system while updating the BIOS! Doing so may cause system boot failure!

When the BIOS update process is complete, the utility reboots the system.

Once the system has been restarted, the following steps need to be completed before starting Windows.

1. Enter the BIOS setup by pressing DEL
2. Once in the setup load the optimized settings by selecting 'Load Optimized Defaults'
3. Exit the setup by selecting 'Save & Exit setup'.
4. Now boot in to windows.

BIOS Setup

This chapter provides basic information on the BIOS Setup program and allows you to configure the system for optimum use. You may need to run the Setup program when:

- An error message appears on the screen during the system booting up, and requests you to run BIOS SETUP.
- You want to change the default settings for customized features.

Note: The items under each BIOS category described in this chapter are under continuous update for better system performance. Therefore, the description may be slightly different from the latest BIOS and should be held for reference only.

➤ Entering Setup

Power on the computer and the system will start POST (Power On Self Test) process. When the message below appears on the screen, press to enter Setup or Press F7 and select 'Enter Setup'.

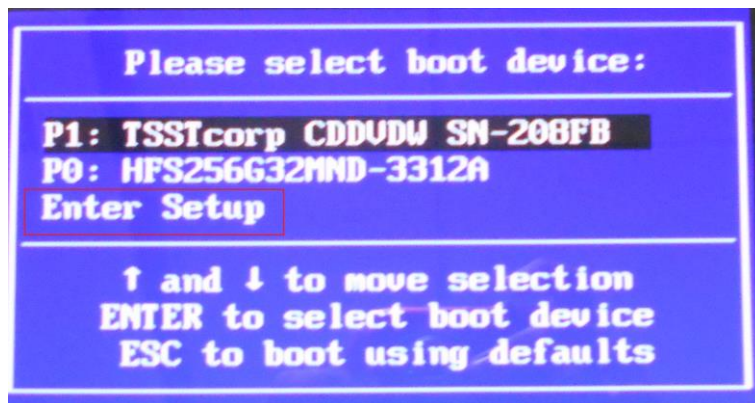

F7 for the Boot Menu

➤ Control Keys

Table 9: BIOS control keys

<← →>	Select Screen
↑↓	Select Item
<Enter>	Select
+/-	Change Opt
F1:	General help
F2:	Previous values
F3:	Optimized Defaults
F4:	Save & Exit
ESC:	Exit

Getting Help

After entering the Setup menu, the first menu you will see is the Main Menu.

Main Menu

The main menu lists the setup functions you can make changes to. You can use the arrow keys (\updownarrow) to select the item. The on-line description of the highlighted setup function is displayed at the bottom of the screen.

Sub-Menu

If you find a right pointer symbol (as shown in the right view) appears to the left of certain fields that means a sub-menu can be launched from this field. A sub-menu contains additional options for a field parameter. You can use arrow keys (\updownarrow) to highlight the field and press <Enter> to call up the sub-menu. Then you can use the control keys to enter values and move from field to field within a sub-menu. If you want to return to the main menu, just press the <Esc >.

General Help <F1>

The BIOS setup program provides a General Help screen. You can call up this screen from any menu by simply pressing <F1>. The Help screen lists the appropriate keys to use and the possible selections for the highlighted item. Press <Esc> to exit the Help screen.

The Menu Bar

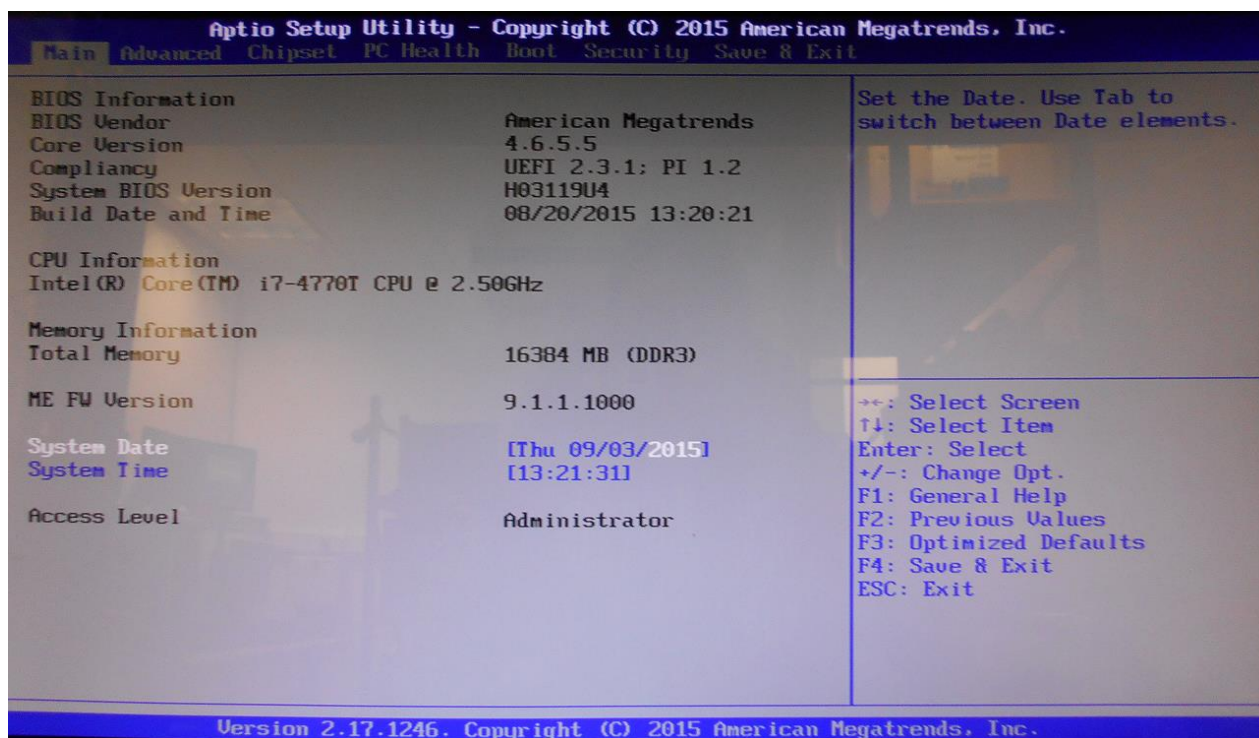

Figure 22: Main Menu

- **Main Menu** - Use this menu for basic system configurations, such as time, date etc.
- **Advanced** - Use this menu to setup the items of the BIOS special enhanced features, integrated peripherals, power management and PC health status.
- **Monitor** - For changing the system monitor configuration settings.
- **Boot** - Use this menu to specify the priority of boot devices.
- **Security** - Use this menu to set supervisor and user passwords.
- **Save & Exit** - This menu allows you to load the BIOS default values or factory

1. **Load Optimized Defaults:** Use the arrow keys (←, →, ↑, ↓) to select the [Restore Defaults] in [Save & Exit] menu, and press <Enter>. A pop-up message will appear, select [Yes] and press <Enter> to load the default settings for optimal system performance.

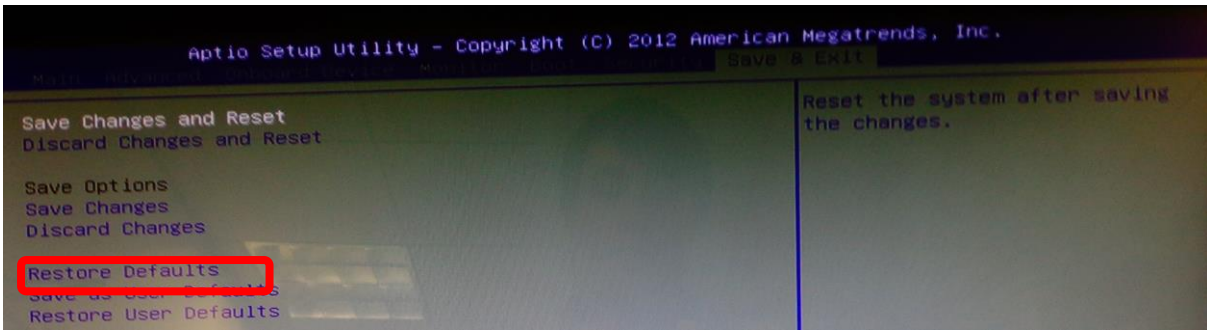

Figure 23: Restore Defaults

2. **Setup Date/Time:** Use the arrow keys (←, →, ↑, ↓) to select the [System Date] / [System Time] in [Main Menu] menu, and press <Enter>. And then, you can set the Date, Time in their respective fields.

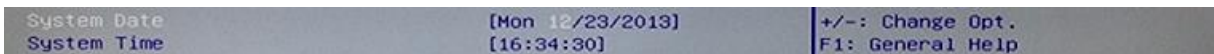

Figure 24: Setup Date/Time

3. **Save & Exit Setup:** Use the arrow keys (←, →, ↑, ↓) to select the [Save Changes & Reset] in [Save & Exit] menu, and press <Enter>. A pop-up message will appear, please select [Yes] and press <Enter> to save the configurations and exit BIOS setup utility.

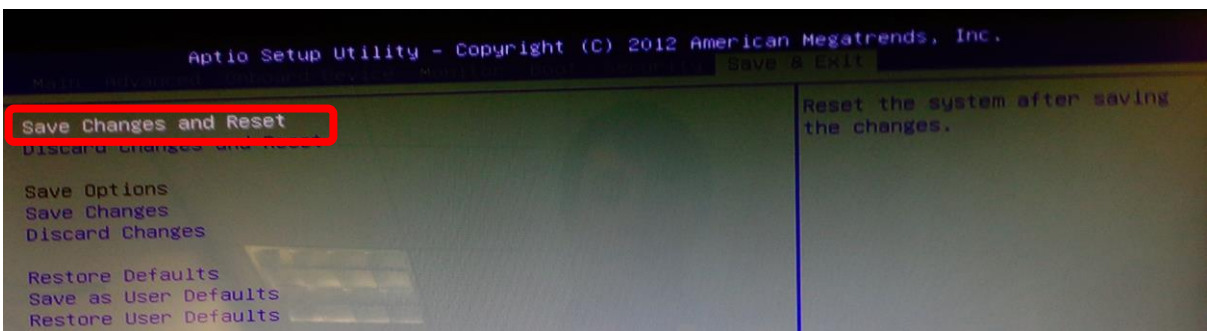

Figure 25: Save & Exit Setup

Windows 8/8.1/10 BIOS Setting

System configured with Windows 8.1/10 will have following default BIOS settings. It is strongly recommended that these BIOS settings are not disabled for a Windows 8/10 system.

OS Boot Mode **[UEFI OS]**
Network Stack **[Enabled]**
Secure Boot **[Enabled]**

To configure Windows 7 on this system the BIOS settings must be changed to boot into Legacy BIOS mode. For Windows 7, OS Boot Mode should be changed to **[Legacy OS]**

Note

Please ensure the changes of the following settings are performed by personnel with some previous experience/knowledge of altering BIOS settings.

Accessing BIOS Setup

To access the BIOS, Press the F7 key during POST for the boot menu to appear and then select 'Enter Setup'

Enabling/Disabling Windows 8/10 Features

1. From the BIOS main menu select the 'Boot' tab.

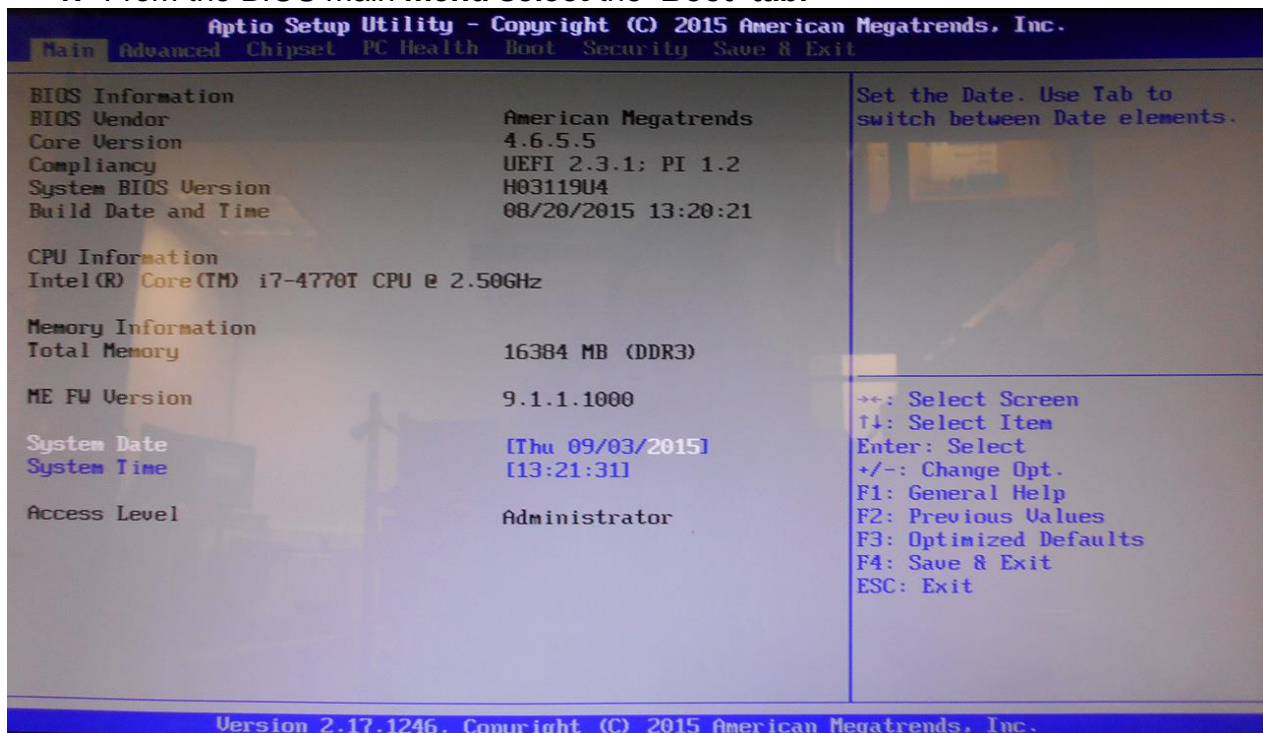

Figure 26: Main menu

2. In the 'Boot configuration menu change following settings:

OS Boot Mode [Legacy OS]
 Launch PXE OpROM policy [Enabled]

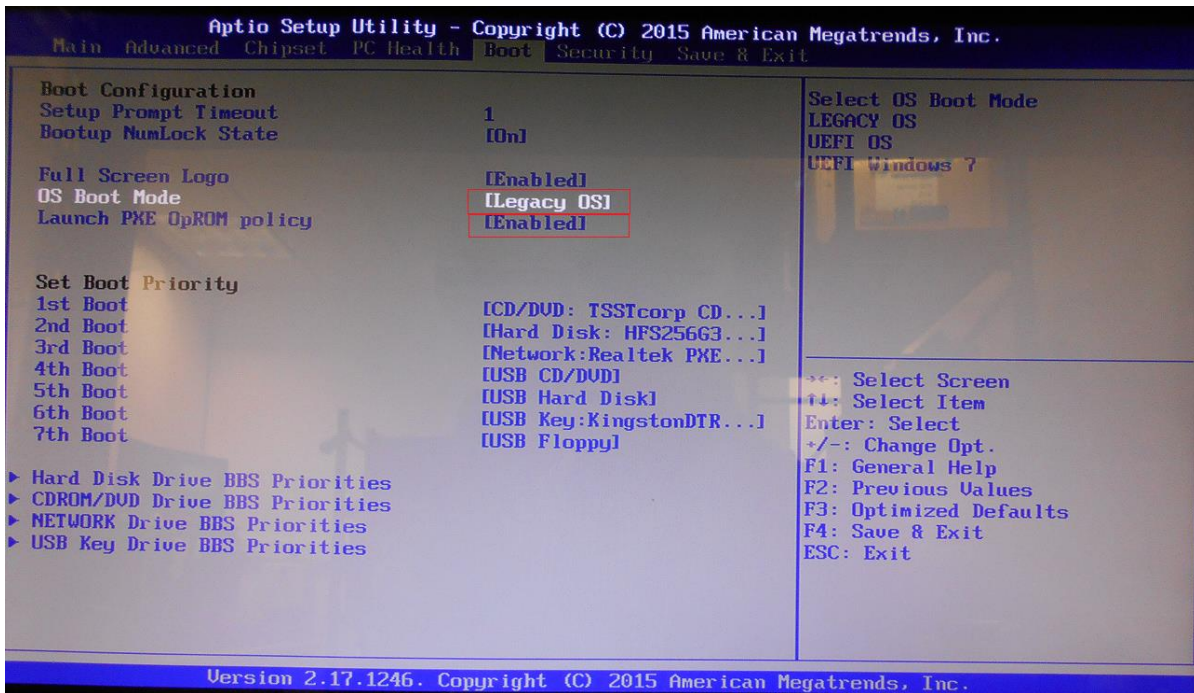

Figure 27: Boot Configuration Menu – Windows 7 settings

For Windows 8.1 and 10 following settings should be set:

OS Boot Mode [UEFI OS]
 Network Stack [Enabled]

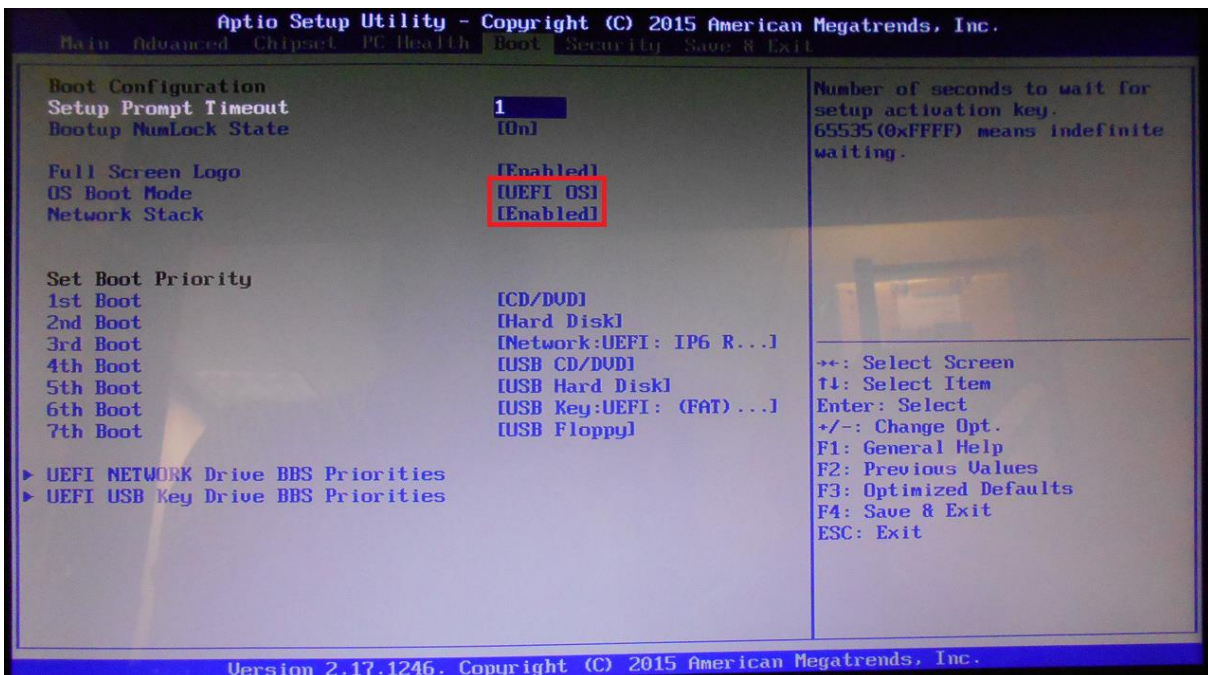

Figure 28: Boot Configuration Menu – Windows 8/10 settings

Enabling Secure Boot

It is recommended that 'Secure Boot' is set to 'Enabled' to initialize the Windows 8/10 secure boot feature when the system boots up.

Note: Secure boot is supported under Windows 8/8.1 and Windows 10. This feature helps in preventing malicious software applications and "Unauthorized" operating systems from loading during the system start-up process.

To Enable Secure Boot

In the Boot configuration menu ensure OS boot Mode is set to [UEFI OS].

1. From the BIOS tab options **select** the 'Security' tab and **select the** 'Secure Boot menu' option.

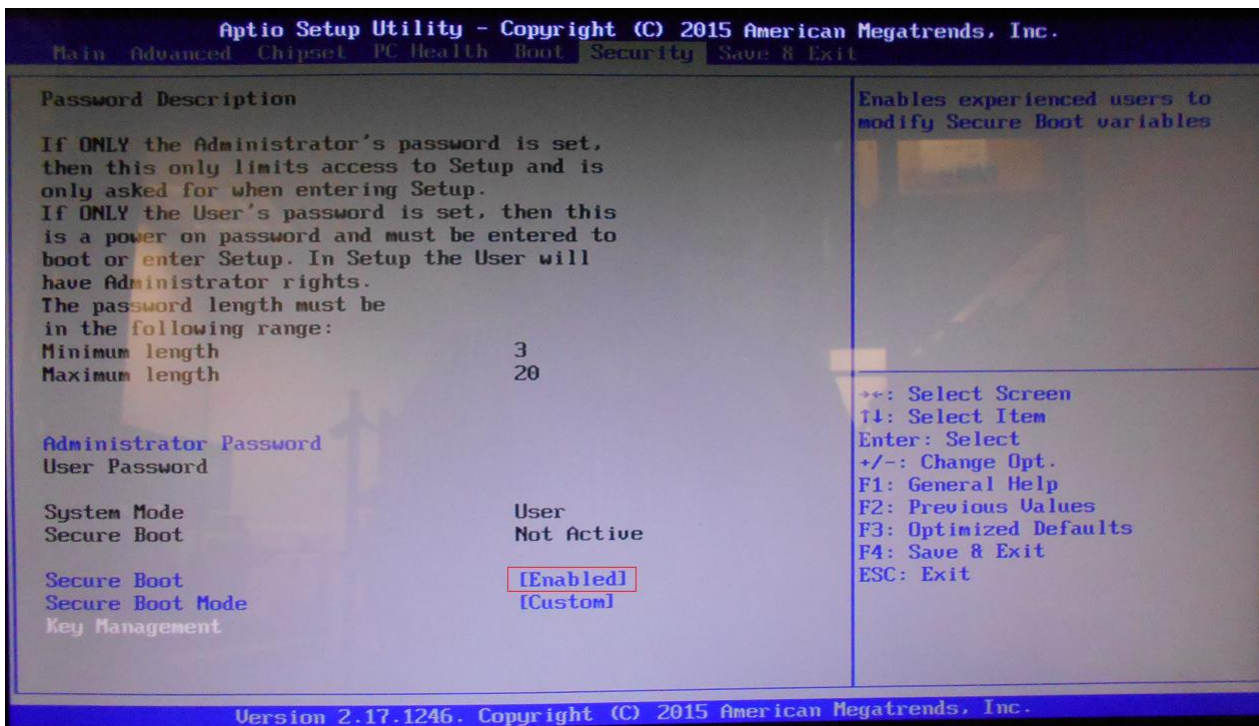

Figure 29: Boot Configuration Menu – Windows 8/10 settings

- Once Secure Boot is set to 'Enabled' set the **Secure Boot Mode** to 'Custom'

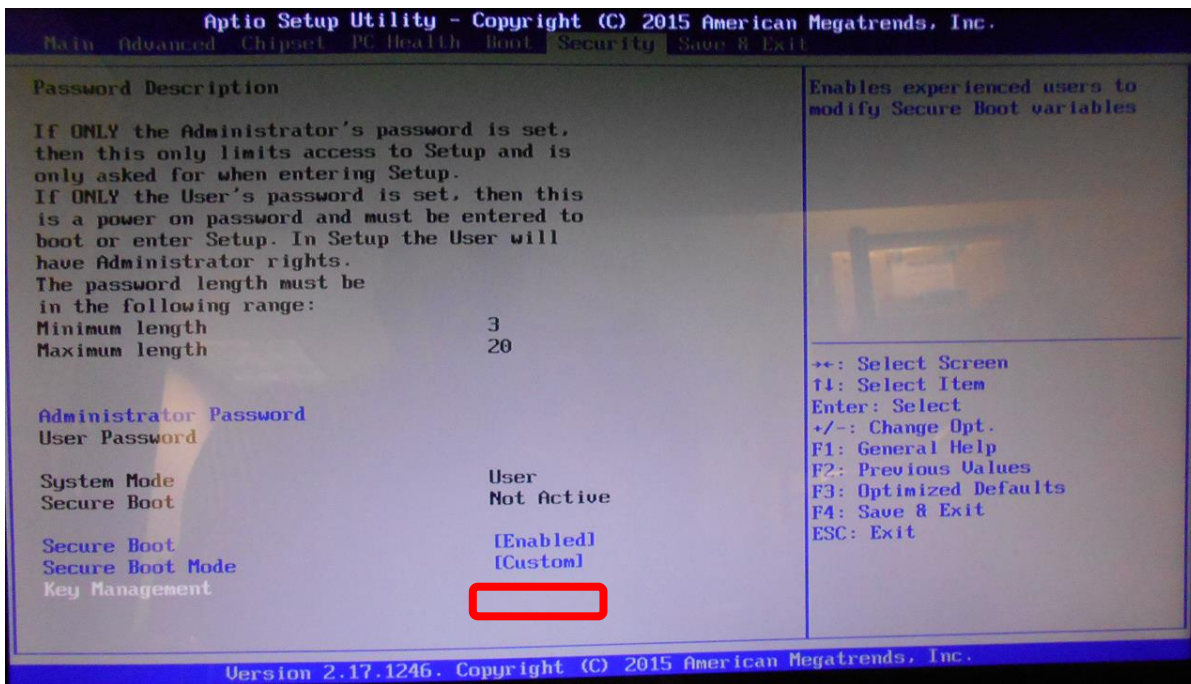

Figure 30: Secure Boot Enabled/Disabled option

- In Custom mode **scroll down** the active options in the Security Tab option list and **Select** the 'Key Management' Option.

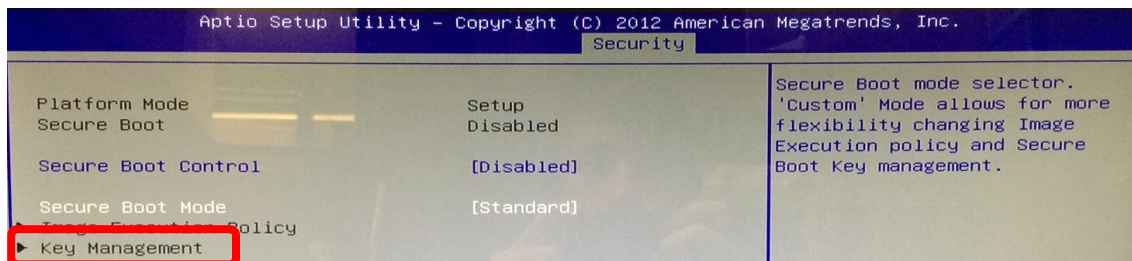

Figure 31: Secure Boot

- In the Key management options **select** the 'Default Key Provisioning' option and **Set** to 'Enabled'

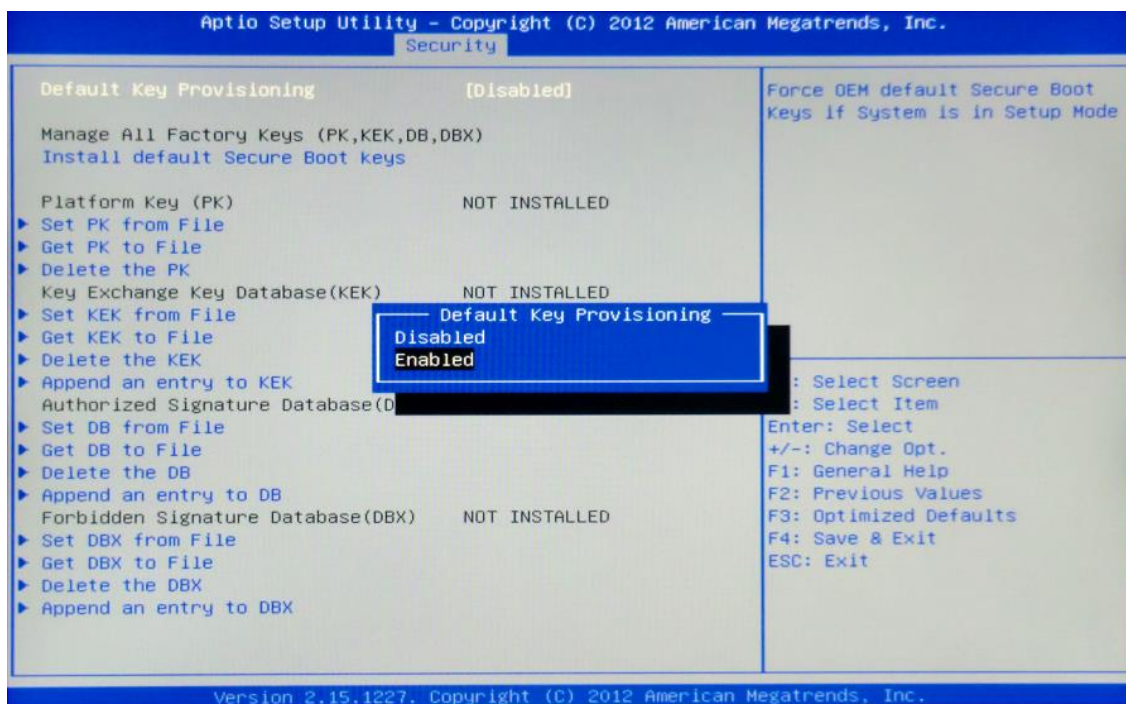

Figure 32: Default Key Provisioning

- In the Key management options **select** the 'Install default Secure Boot Keys' option and **confirm** Installation in the pop up to install the default secure Boot Keys.

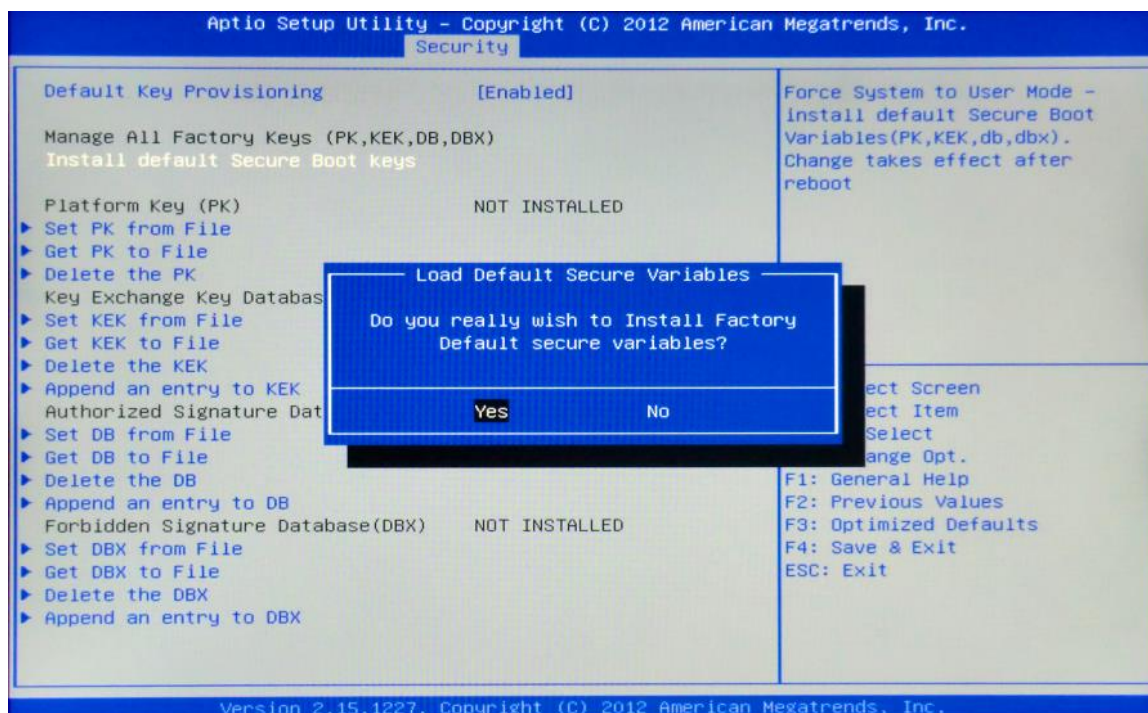

Figure 33: Default Secure Boot Keys

5. Once the Default Secure Boot keys are installed it will state 'Installed' as shown in below image

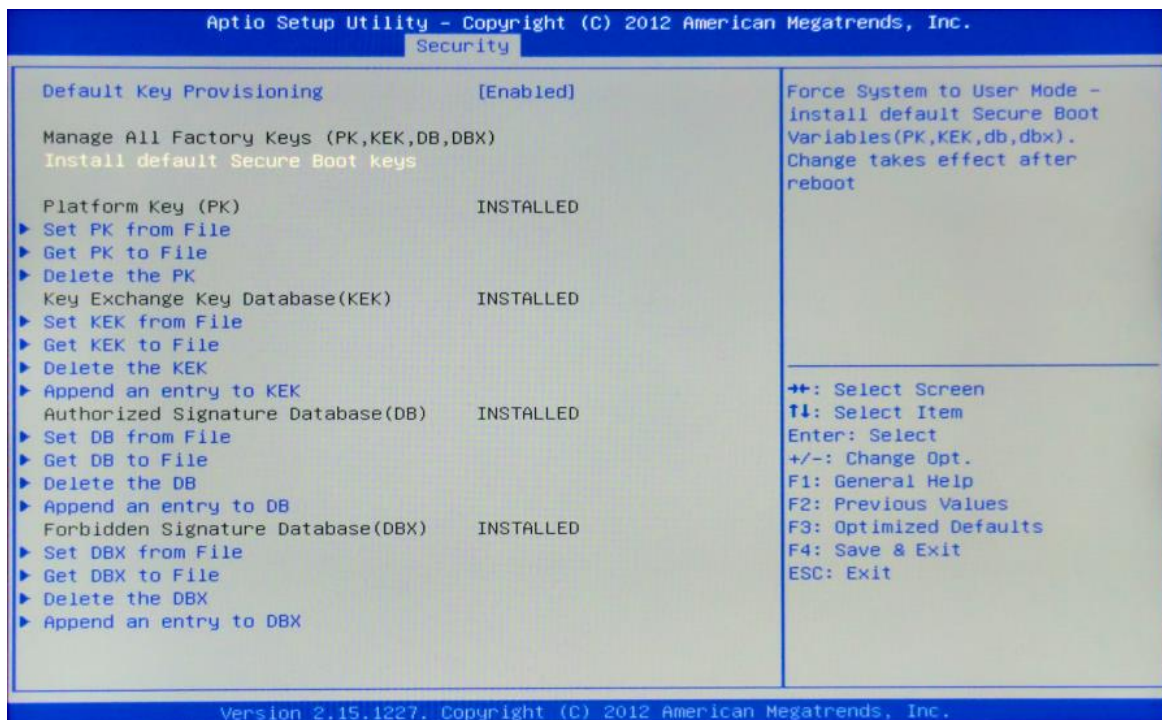

Figure 34: Default Secure boot keys

Disabling Secure Boot

1. In the **Key management options** select '**Default Key Provisioning**' and Set the option to 'Disabled'

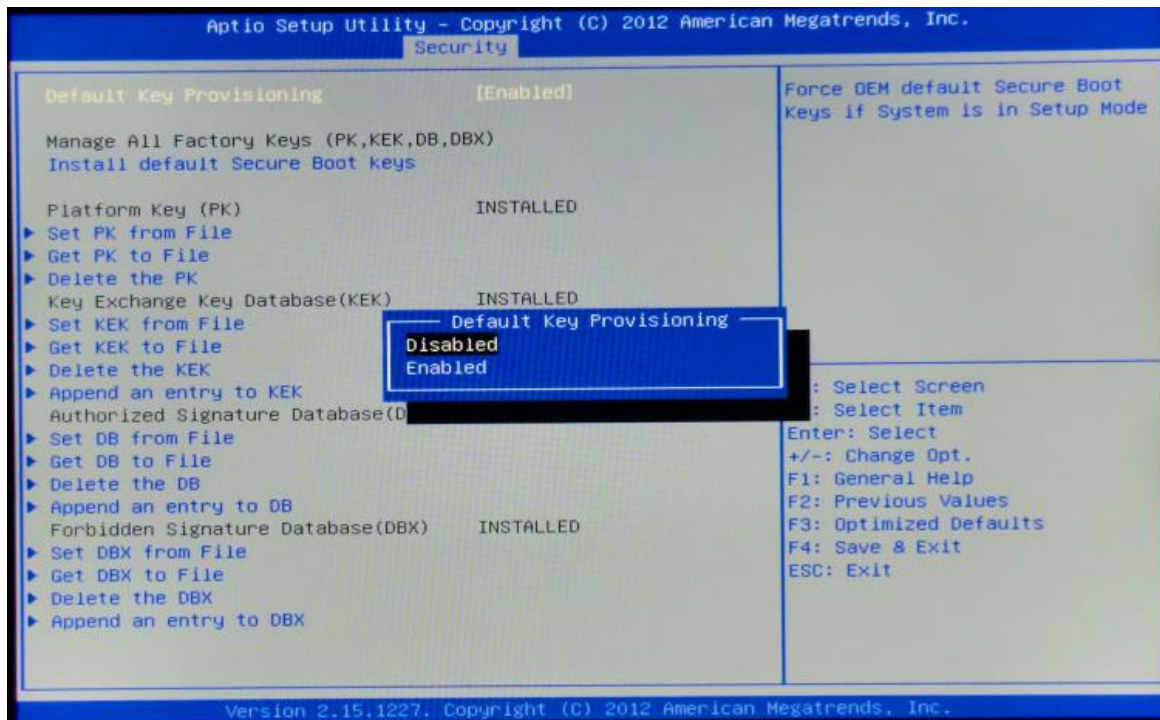

Figure 35: Default Key Provisioning

2. **Select** 'Clear Secure Boot Keys' and **confirm** Installation in the prompt pop up to clear the default secure Boot Keys.

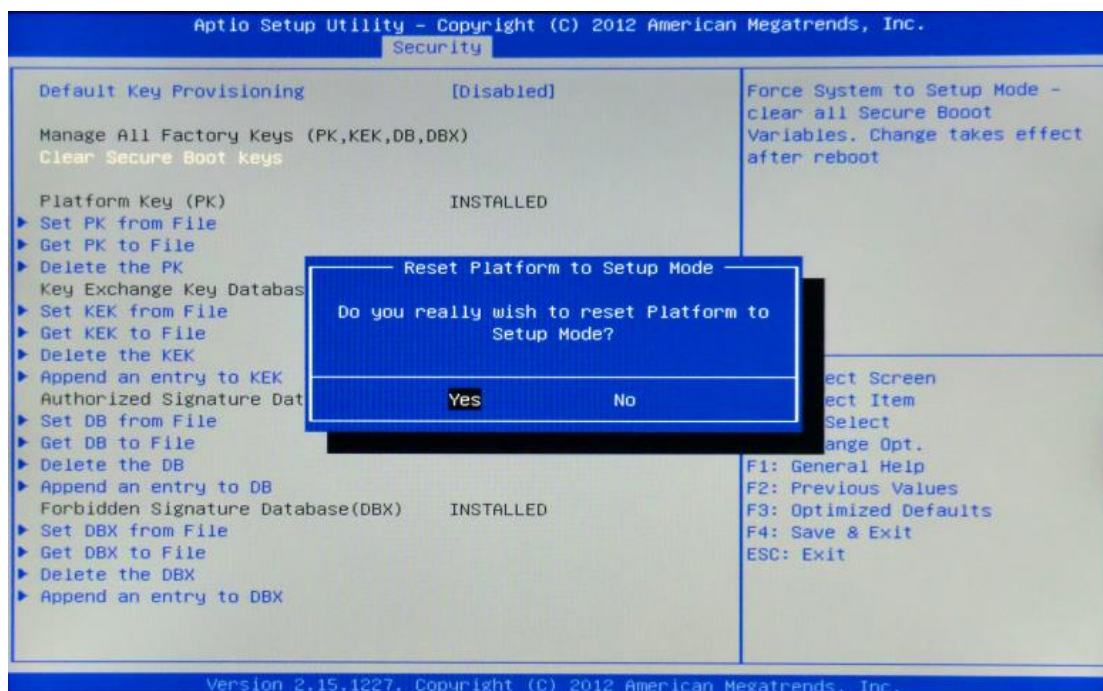

Figure 36: Reset platform

- Once the secure Boot keys are cleared it will state '**Not Installed**' as shown in below

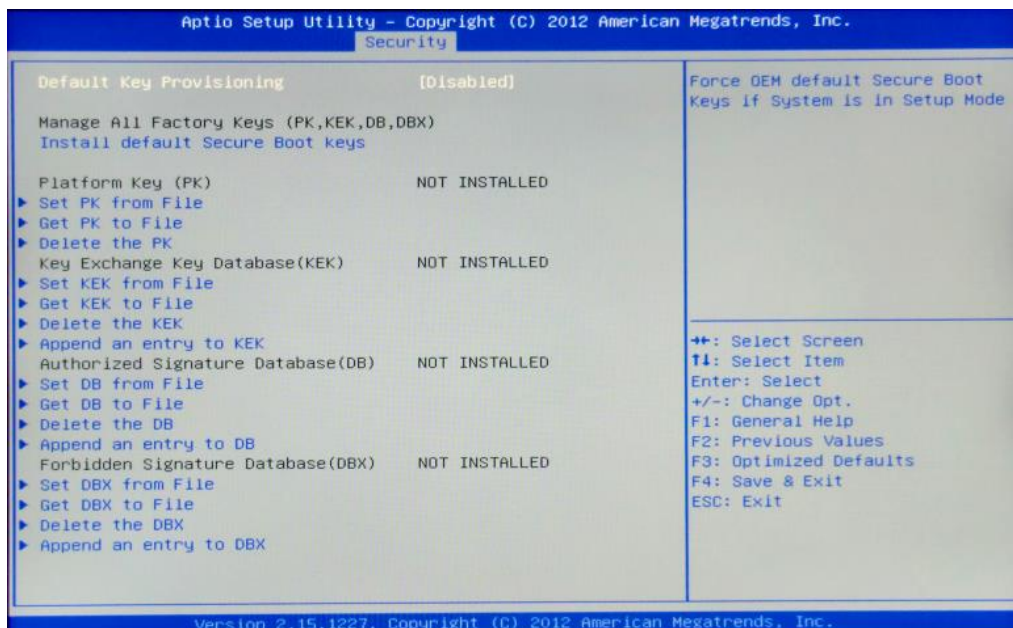

Figure 37: Clear Secure Boot Keys'

- Press Esc to exit the Key provisioning Menu.
- Select 'Secure Boot' and set the option to 'Disabled'**

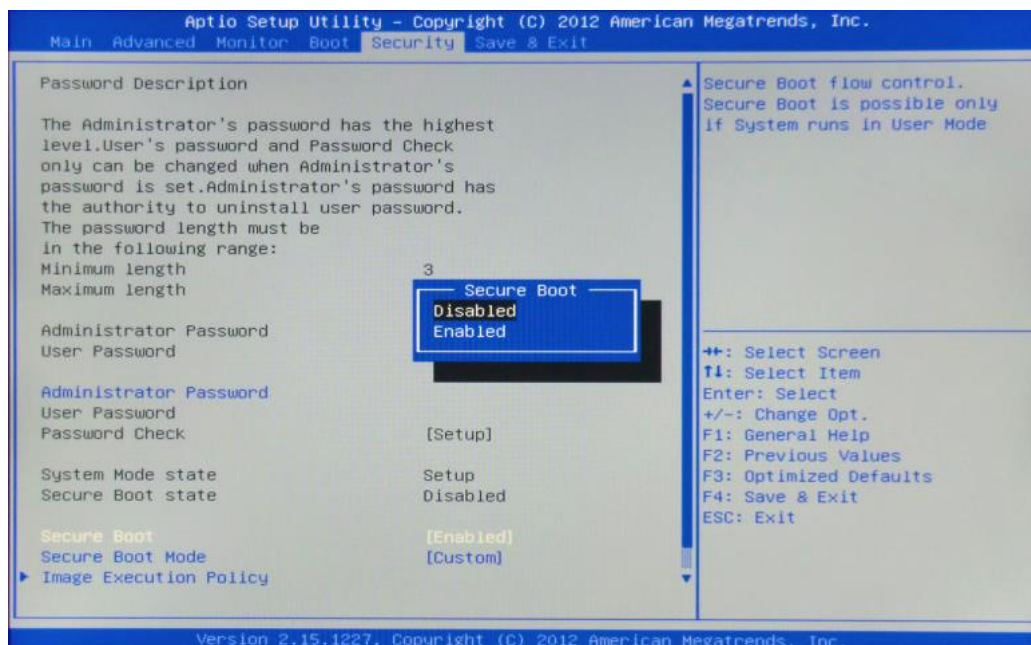

Figure 38: Disabling Secure boot

Once all BIOS settings have been configured press F4 key to Save and Exit the BIOS Setup.

For Non UEFI OS support (Windows 7) secure boot keys must be set to default and secure boot disabled. Otherwise system will not detect SATA hard disk drive under boot menu.

Chapter 5: Suggestions

Viglen is interested in continuing to improve the quality and information provided in their manuals. Viglen has listed some questions that you may like to answer and return to Viglen. This will help Viglen to keep and improve the standard of their manuals.

1. Is the information provided in this and other manuals clear enough?

2. What could be added to the manual to improve it?

3. Does the manual go into enough detail?

4. Would you like an on-line version of this manual?

5. How do you rate the Viglen Technical support and Service Departments?

6. Are there any technological improvements that could be made to the system?

7. Other points you would like to mention?

Please return this slip to: Product Development Dept.
XMA Ltd.
7 Handley Page Way
Colney Street
St Albans
Hertfordshire
AL2 2DQ

