

Viglen Desktop PC Getting Started Guide

Step 1:



Place the computer base unit on or under your desk, depending on your personal preference.

Place the keyboard, monitor and mouse on the desk to suit your requirements. Remember that the keyboard and mouse should fall naturally under your hands when in use.

The top of the monitor screen should be just below eye level to provide comfortable use.

Step 2:



Connect the AC power supply cable into the back of the PC base unit. Connect the monitor AC power supply cable into the back of the monitor.
Note: Please DO NOT plug the AC Power supply cable into a wall socket at this point.

Step 3:

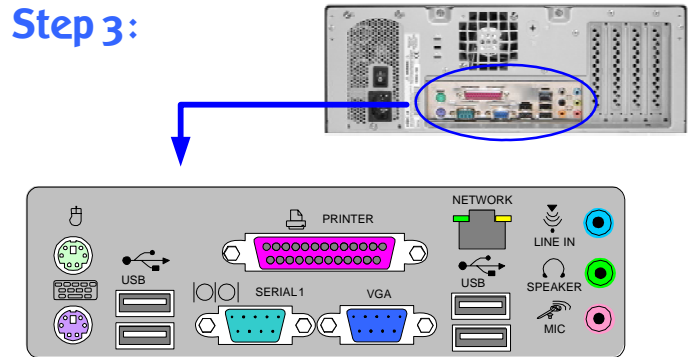

Located at the rear of the base unit is an 'Interface panel'. This is where you connect the peripheral devices that come with your Viglen PC. If your system has an 'onboard' sound card, the audio ports will be accessible. If these ports are covered, your system either has an 'add-in' sound card or no audio available. This also applies if an 'add-in' graphics card has been installed in your Viglen PC.

Note: On certain models the ports may be arranged differently. ALWAYS match the cables with the colours specified.

Step 4:

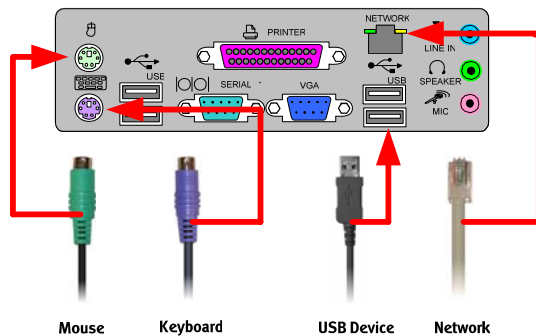

Connect the mouse to the GREEN socket, and the keyboard to the PURPLE socket.

If a USB device or Network is available then connect to the relevant sockets located on the 'Interface Panel' at this point.

Step 5:

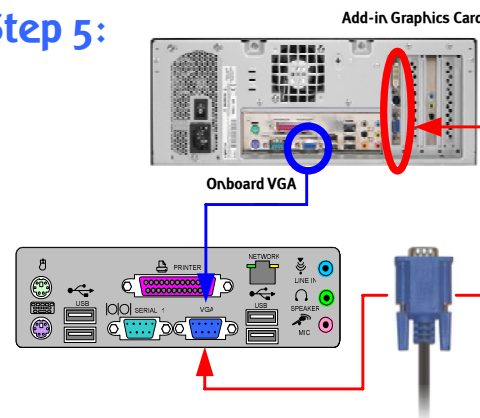

Plug the video signal cable into the BLUE VGA connector on the back of the PC base unit. On some models, the VGA connector will be located on the 'Interface Panel'. Both options are shown in this step.

Step 6:

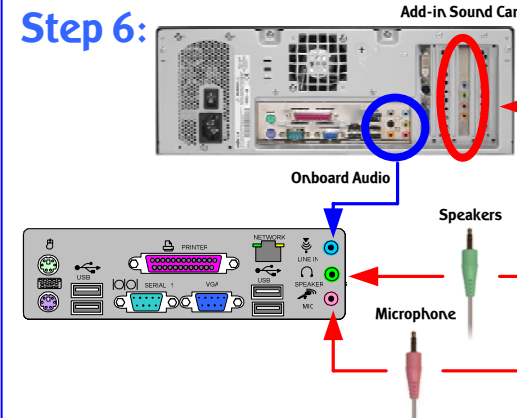

Plug the stereo speaker cable into the LIGHT GREEN socket, and plug the microphone cable into the PINK socket. On some models the audio will be onboard and the ports will be located on the 'Interface Panel'. Both options are shown in this step.

Step 7:

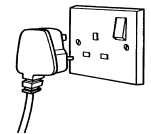

Plug the AC Power supply cable into a wall socket and switch on.



Located on the PSU is a master power switch for your Viglen PC. Make sure its in the on position before pressing the power button, located at the front of the base unit.

Viglen System Recovery Utility

Under certain conditions you may need to reset the software originally installed on your computer to factory conditions. This can be put down to many different reasons:

- Accidental deletion of system files.
- Incompatible software has been installed.
- Incompatible changes to the system settings.

At Viglen, we understand that unless you have professional knowledge of computer systems, reinstallation can be a costly and time-consuming affair, especially for new users. This is why we have created the Viglen Recovery Utility System – designed to automatically reinstall your computer software quickly and efficiently.

Before proceeding with system recovery, please observe the following recommended guidelines.

- Back up all personal files to a CD or a suitable backup device before proceeding with the recovery procedure.
- Any subsequent software installed by the user must therefore be manually reinstalled – Please refer to the manuals that came with your software for installation instructions.
- Once initiated, all data stored on the system will be destroyed and will therefore not be recoverable.

Using the Recovery Utility

Please read the recommended guidelines above before continuing with the recovery procedures:

1. Shutdown your Viglen PC (if applicable) and switch off.
2. Insert the Viglen Recovery Utility CD into the CD-ROM drive.
3. Switch your computer back on.
4. The Viglen Recovery Utility CD will now load.
5. When prompted, please type 'factory' and press the 'Enter' key to initiate system recovery.
6. A Windows style screen will now appear with two horizontal bars showing the status of the recovery sequence. Please wait while the procedure completes.
7. When prompted, remove the Recovery Utility CD from the drive and press a key to restart the computer.

Windows will now start up and you will be prompted to enter your User Information – Please refer to the Software Guide supplied with your Viglen PC.

Your Viglen Recovery Utility CD....

WARNING: ONLY TO BE USED IF YOUR VIGLEN PC HAS BECOME UNSTABLE OR YOU HAVE BEEN ADVISED OTHERWISE BY A MEMBER OF VIGLEN TECHNICAL SUPPORT. ALL PERSONAL DOCUMENTS WILL BE LOST IF THIS CD IS ACTIVATED.

Hopefully, you should never need to use this utility, but in the unfortunate event that your system must be reinstalled, please keep this Getting Started Guide and the Viglen Recovery Utility CD in a safe place to help ensure a hassle-free recovery.

Getting Help at Viglen

Technical Support

If you have any queries concerning the following:

- 1) Hardware configuration problems.
- 2) You wish to return your hardware for repair or arrange a service visit (subject to contract).
- 3) You have installation or set up difficulties.
- 4) You require additional drivers.

Please call our TECHNICAL SUPPORT department on **01727 201 850**

Customer Care

If you have any queries concerning the following:

- 1) Parts missing or damaged from your Viglen PC order.
- 2) Incorrect goods supplied against your Viglen PC order.
- 3) Any complaint with a courier or delivery in general.
- 4) Collection of any computers or parts.
- 5) You have ordered or wish to order spare parts.
- 6) You wish to return your Viglen PC for an upgrade.
- 7) You wish to know the status of any returned Viglen PC.
- 8) You require information on upgrading new or old systems.

Please call our CUSTOMER CARE department on **01727 201 810**

IMPORTANT

Please read this pamphlet before switching on the Viglen PC and store in a safe place. For further information regarding your Viglen PC please refer to the Viglen Driver CD which includes the BIOS, Drivers and Manual for your motherboard.

Viglen Limited
7 Handley Page Way
Old Parkbury Lane
Colney Street
St Albans
Hertfordshire AL2 2DQ
Tel: 08705 922 922
Fax: 01727 201 888
www.viglen.co.uk

Corporate Sales:
01727 201 830
Education Sales:
01727 201 860
Public Sales:
01727 201 830
Schools Sales:
01727 201 820

Viglen is a trademark of Viglen Ltd, Viglen Ltd is a subsidiary of Viglen Technology Ltd. Pentium 4 is a registered trademark of Intel Corporation. Viglen Ltd disclaims any proprietary interest in trademarks and trade names other than its own. Viglen cannot be liable for pictorial or typographical errors. Viglen reserve the right to change the specification of the servers without prior notification. Specifications may be subject to change without notice. Although Viglen endeavours to ensure the accuracy of this information, Viglen will not be liable for any damages whatsoever for errors or omissions of fact herein. Viglen, Contender, Genie and Dossier are registered trademarks of Viglen Ltd. Microsoft, MS-DOS and Windows are registered trademarks of Microsoft Corporation. Intel, Intel logo, Intel Inside, Intel Inside logo and Pentium are trademarks or registered trademarks of Intel Corporation or its subsidiaries in the United States and other countries All other trademarks are acknowledged. Subject to Viglen terms and conditions available on request.

